



US 20130120636A1

(19) **United States**
(12) **Patent Application Publication**
Baer

(10) **Pub. No.: US 2013/0120636 A1**
(43) **Pub. Date: May 16, 2013**

(54) **ILLUMINATION SYSTEM**

(52) **U.S. Cl.**

(75) Inventor: **Richard L. Baer**, Los Altos, CA (US)

USPC **348/335; 348/370; 348/E05.024**

(73) Assignee: **Apple Inc.**, Cupertino, CA (US)

(57) **ABSTRACT**

(21) Appl. No.: **13/293,936**

A method for capturing an image with an image capture device, such as a camera or mobile electronic device. The method includes initiating a master-slave relationship between the image capture device and at least one secondary device. Once the master-slave relationship is initiated, remotely activating one of an at least one light source of the at least one secondary device. As the light source is activated, capturing a test image of a scene illuminated by the at least one light source by the image capture device. Then, analyzing the test image to determine if an illumination of the scene should be adjusted and if the illumination of the scene is to be adjusted, providing a control signal to the at least one secondary device including at least one of a position instruction, an intensity level, or timing data.

(22) Filed: **Nov. 10, 2011**

Publication Classification

(51) **Int. Cl.**
H04N 5/225 (2006.01)

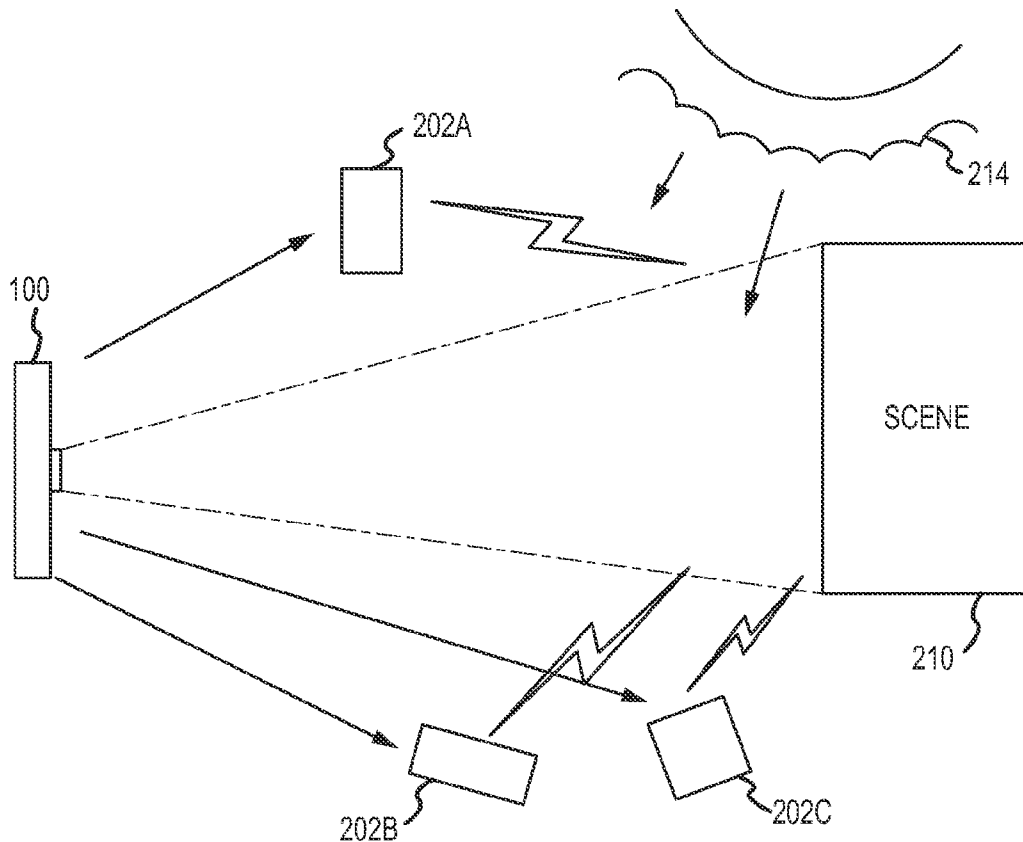

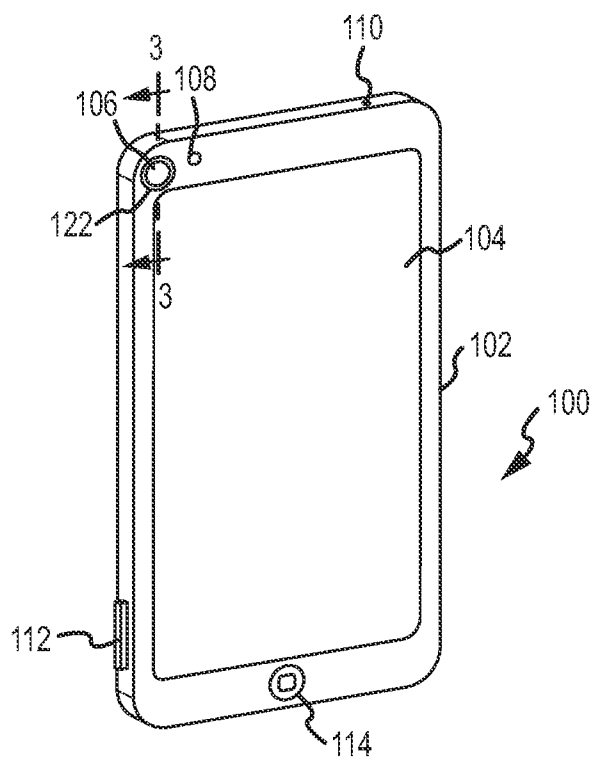

FIG. 1A

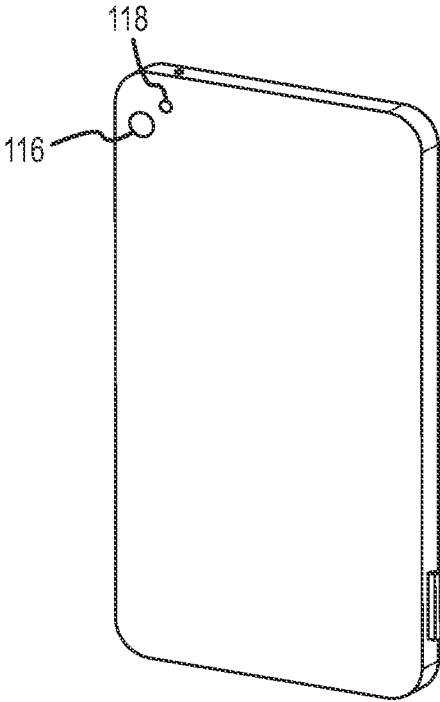

FIG.1B

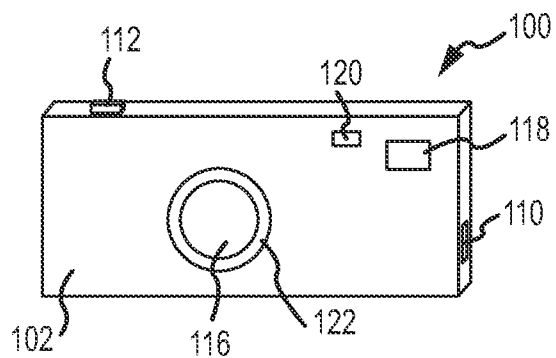

FIG. 2A

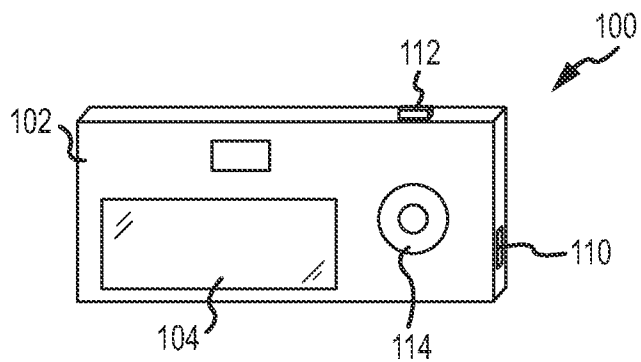

FIG. 2B

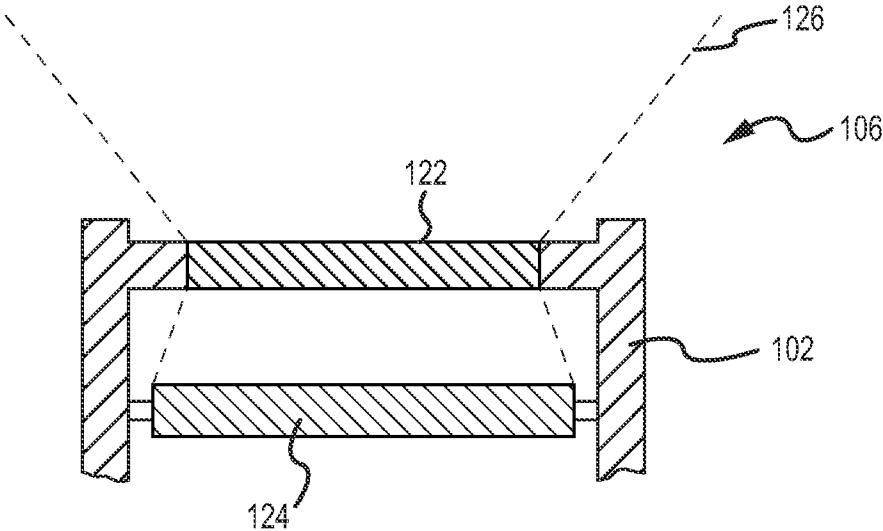

FIG.3

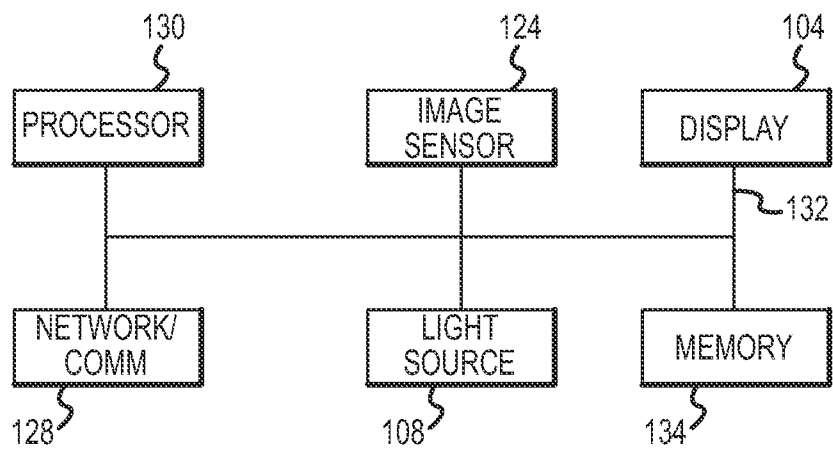

FIG.4

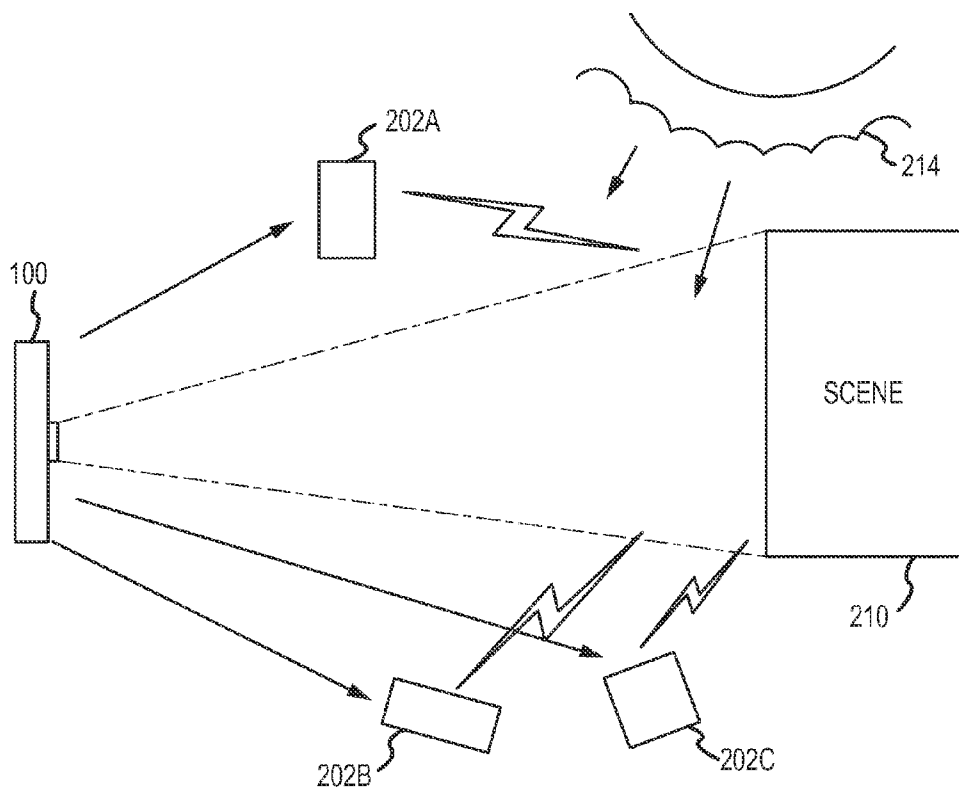

FIG.5

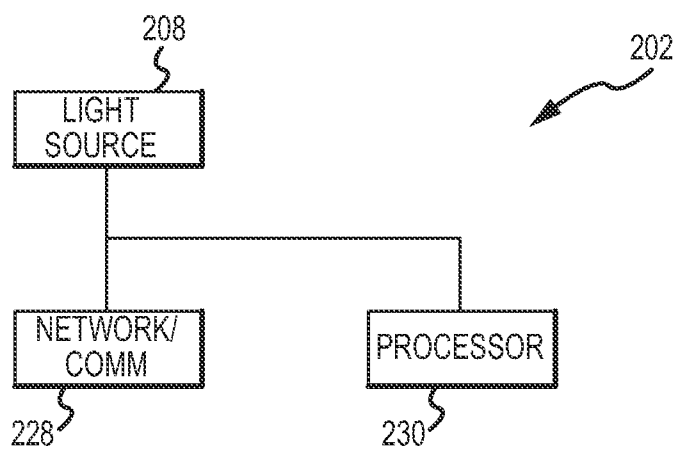

FIG.6

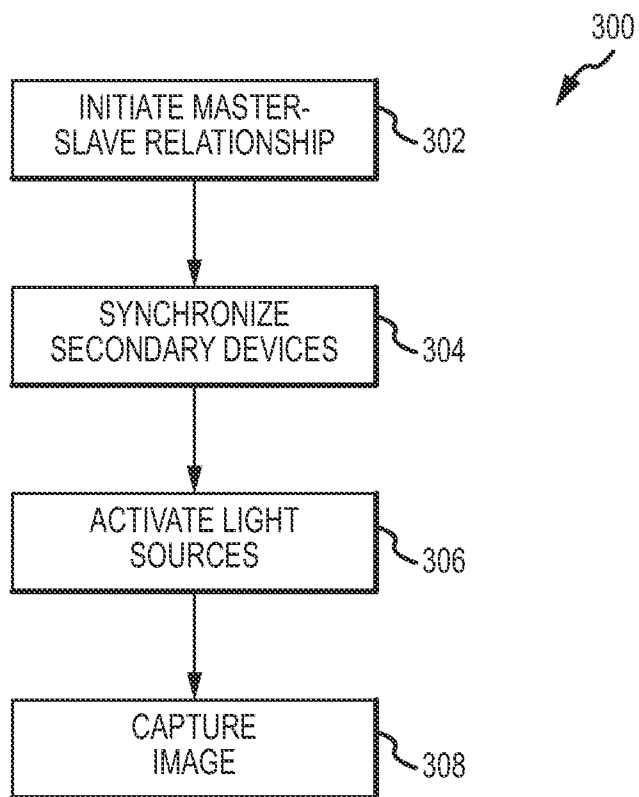

FIG.7

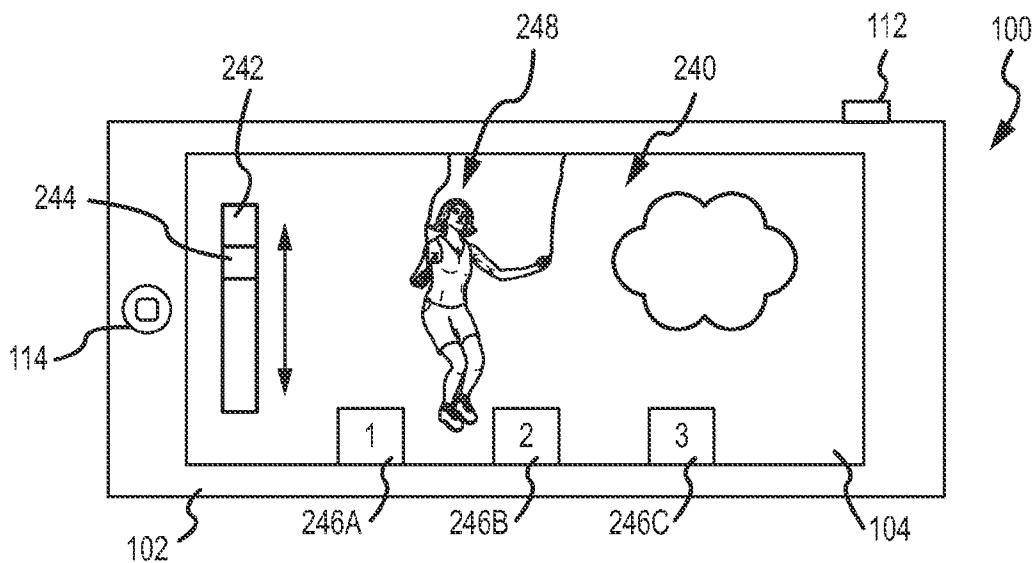

FIG. 8

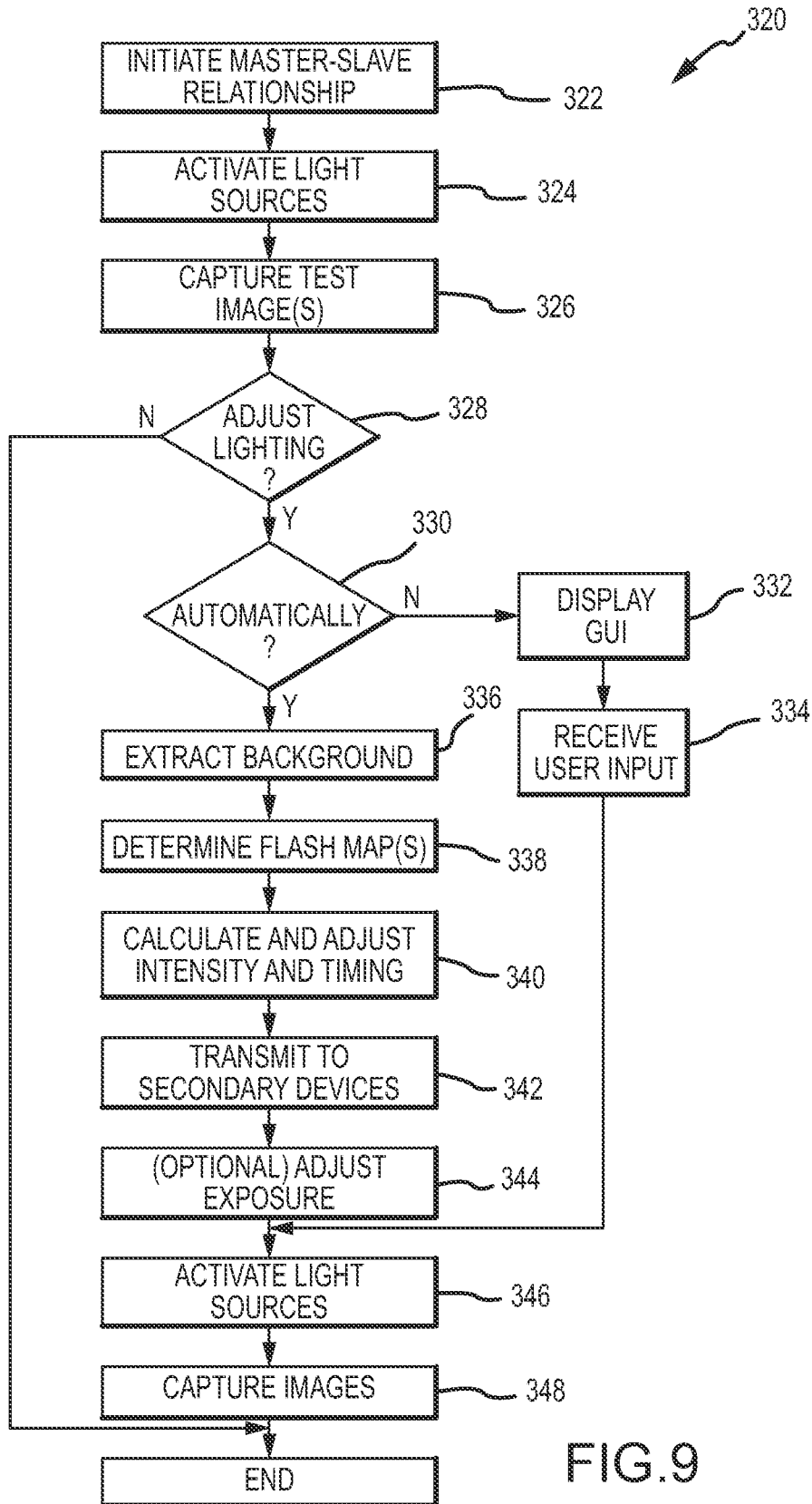

FIG.9

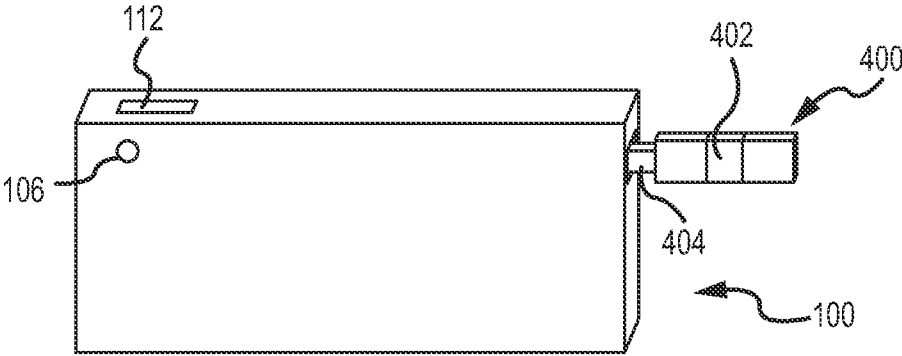

FIG. 10

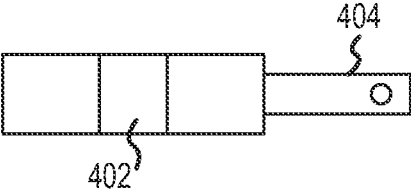

FIG.11A

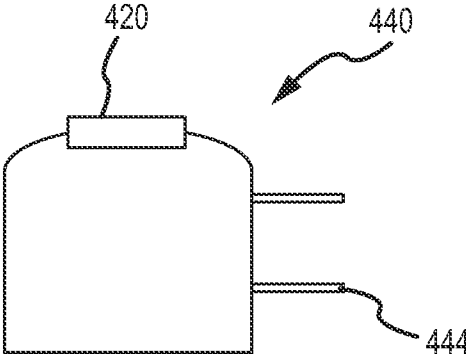

FIG.11B

ILLUMINATION SYSTEM

TECHNICAL FIELD

[0001] The present invention relates generally to using multiple strobes to provide lighting for a scene to be captured by a camera.

BACKGROUND

[0002] Many cameras include a strobe or flash for capturing photographs or images in low light. The range of these integrated flashes may be limited. For example, a typical flash may have a light intensity that decreases by a square of the distance from the source. Use of these integrated flashes may lead to photographs having harsh foreground lighting but poor or no background lighting since the flash originates from the camera and may cast strong shadows as light intensity decreases with a square of the distance from the camera. Additionally, corners of a captured image may have a significant decrease in intensity as the width of the flash may be limited.

[0003] Additionally, many photographs taken by cameras having an integrated flash may show the “red-eye” phenomenon, where the subject’s eyes appear red. This occurs because the flash is typically located near a lens of the camera, and thus a person or animal may be facing the flash as the image is taken. Red-eye reflections are typically due to light from the flash being focused straight on a person or animal and, due to the high frequency of the flash, the eye does not have time to close. This results in light from the flash being reflected off a retina of the person or animal’s eye; this reflected light is then captured by the camera. Increasing a separation between the flash and the lens can decrease the occurrence of red-eye reflections. However, in small cameras or devices (e.g., smart phones with an integrated camera) this may be difficult to achieve.

SUMMARY

[0004] Examples of embodiments described herein may take the form of a method for capturing an image with an image capture device, such as a camera or mobile electronic device. The method includes initiating a master-slave relationship between the image capture device and at least one secondary device. Once the master-slave relationship is initiated, remotely activating one of an at least one light source of the at least one secondary device. As the light source is activated, capturing a test image of a scene illuminated by the at least one light source by the image capture device. Then, analyzing the test image to determine if an illumination of the scene should be adjusted. If the illumination of the scene is to be adjusted, providing a control signal to the at least one secondary device including at least one of a position instruction, an intensity level, or timing data.

[0005] Other embodiments may take the form of an electronic device. The electronic device includes a lens, an image sensor in optical communication with the lens, and a processor in communication with the image sensor. The electronic device further includes a communication mechanism in communication with the processor and configured to transmit and receive a control signal to one or more secondary devices. The control signal controls a light source of the one or more secondary devices.

[0006] Still other embodiments may include a method for capturing an image of a scene with an image capture device.

The method may include initiating a master-slave relationship between the image capture device and an at least one secondary device including a remote light source. When the master-slave relationship has been initiated, remotely activating a remote light source of the secondary device. As the remote light source is activated, capturing a first image of the scene illuminated by the remote light source. Then, constructing a flash map corresponding to the secondary device.

BRIEF DESCRIPTION OF THE DRAWINGS

[0007] FIG. 1A is a front perspective view of a first embodiment of an image capture device.

[0008] FIG. 1B is a rear perspective view of the image capture device of FIG. 1A.

[0009] FIG. 2A is a front perspective view of a second embodiment of the image capture device.

[0010] FIG. 2B is a rear perspective view of a the image capture device of FIG. 2A.

[0011] FIG. 3 is a cross-sectional view of the image capture device taken along line 3-3 in FIG. 1A.

[0012] FIG. 4 is an example block diagram of the image capture device.

[0013] FIG. 5 is a top elevation view of an illumination system utilizing the image capture device.

[0014] FIG. 6 is a block diagram of a secondary device of the illumination system.

[0015] FIG. 7 is a flow chart illustrating an example method for capturing an image.

[0016] FIG. 8 is a front elevation view of the image capture device of FIG. 1A displaying a graphical user interface.

[0017] FIG. 9 is a flow chart illustrating an example method for modifying an illumination of a scene and capturing an image of the scene.

[0018] FIG. 10 is a rear perspective view of the image capture device of FIG. 1A including a remote light source.

[0019] FIG. 11A is a front perspective view of a first embodiment of the remote light source.

[0020] FIG. 11B is a front perspective view of a second embodiment of the remote light source.

SPECIFICATION

[0021] Some embodiments described herein may take the form of an illumination system. The illumination system may include an image capture device and one or more secondary (or “slave”) devices, each including one or more light sources. The light sources of each secondary device may be activated by the image capture device in order to illuminate a scene prior to the image capturing device taking an image of the scene. In one example, the image capture device communicates with each secondary device and, as the image capture device is about to capture an image of the scene, each secondary device activates its light source. The image capture device may automatically adjust the timing and/or intensity of each secondary device or a user may manually adjust an intensity and/or timing of the light sources.

[0022] Furthermore, the image capture device may provide instructions to a user regarding the placement of each secondary device around a particular scene in order for a desired illumination in a captured image. Likewise, the image capture device may relay such instructions to persons interacting with each of the secondary devices. These relayed instructions may be personalized for each different secondary device. In some embodiments, the instructions may control timing,

intensity, duration, and/or angle of the flash. The instructions may also be visible to the persons interacting with each secondary device and may contain instructions for the persons. As one example, a display associated with (or incorporated into) a secondary device may display text instructing a person holding that device to move in a particular direction, for a particular distance, to angle or move the device in a certain manner, and so forth. The secondary device may track its orientation and/or position in absolute or relative terms and determine if the instructions have been followed. This information, in turn, may be relayed to the image capture device. In some embodiments, the image capture device may delay taking an image until all secondary devices relay to it data confirming the instructions have been followed.

[0023] In one embodiment, the image capture device and the slave devices are mobile electronic device such as smart phones, tablet computers, personal digital assistants, digital cameras and the like. In this embodiment, the image capture device may be the same type of device as the other secondary devices, but act as a master device controlling certain operations of each slave. In another embodiment, the image capture device may be different than the secondary devices. For example, the image capture device may be a camera including a communication mechanism and the secondary devices may be light sources with a communication mechanism. The image capture device may be in communication with the secondary devices wirelessly, e.g., via Bluetooth, WiFi, radio frequency signals, infrared signals and so on. Accordingly, the image capturing device may communicate with each secondary device in order to adjust an intensity of the light sources, the timing of activation of the light sources, and any other desired parameters.

[0024] In the embodiments disclosed herein, the light sources may be triggered or activated based on a wireless signal from the image capture device. Similarly, a clock in each secondary device may be synchronized with a clock in the image capture device, and the image capture device may provide a time that each light source should flash. The above embodiments ensure that the secondary devices may only be activated in response to a control signal from the image capture device.

[0025] In prior art strobe or flash systems, each strobe may discharge in response to a light pulse, one example of which is a xenon gas flash having an optical detector. Accordingly, in some instances these strobes may accidentally discharge in response to a flash from another camera or another non-system source. By contrast, the secondary devices of the present disclosure generally are in communication with each other and the image capture device via a specific communication mechanism. In some instances, the communication may be over a secured communication path for example, the secondary devices may be paired with the image capture device on a Bluetooth communication system. Thus, the light sources of the secondary devices may be triggered only when desired, such as through a transmitted instruction.

[0026] Further embodiments provide a method of providing illumination of a scene in order to capture an image of the scene. The electronic device may capture one or more test images and may analyze each test image in order to determine whether the lighting of the scene should be changed. If the lighting should be altered, the image capture device may communicate with the secondary devices to adjust the timing and/or intensity of the light source for each flash. For example, the image capture device may decrease the intensity

of the light sources for secondary devices closer to the image capture device and may increase the intensity of the light sources of secondary devices farther from the image capture device. Thus, the image capture device may capture an image of a scene that is substantially uniformly lit, or otherwise illuminated according to a desired scheme.

[0027] In one embodiment, the image capture device may include a user interface allowing a user to selectively adjust the illumination of a scene prior to an image of the scene being captured. In another embodiment, the image capture device may adjust the illumination of the scene substantially automatically, e.g., through image processing techniques.

[0028] Furthermore, other embodiments of the present disclosure may include a remote flash device or removable light source for the image capture device. The remote flash device may be incorporated into a charging device for the image capture device, or may otherwise include a connector that may be received within an input port of the image capture device.

The Image Capture Device

[0029] The methods and devices described herein can be used with substantially any type of apparatus or device that may capture an image. FIG. 1A is a front perspective view of an example embodiment of an image capture device **100**. FIG. 1B is a rear perspective view of the image capture device **100**. As shown in FIGS. 1A and 1B, in some instances the image capture device **100** may be a mobile electronic device, such as, but not limited to, a smart phone, digital music player, cellular phone, gaming device, tablet computer, notebook computer and so on. In these instances, the mobile electronic device may have an incorporated camera or image sensing device so as to function as the image capture device. However, in other embodiments, the image capture device may be a stand-alone camera or a camera otherwise incorporated into another type of device. FIG. 2A is a front perspective view of another embodiment of the image capture device **100**. FIG. 2B is a rear perspective of the embodiment of image capture device **100** of FIG. 2A.

[0030] Referring to FIGS. 1A-2B, the image capture device **100** may include an enclosure **102**, a display **104**, a camera **106**, a light source **108**, one or more input mechanisms **112**, **114**, and an input port **110**. The enclosure **102** may at least partially surround components of the image capture device **100** and provides a housing for those components.

[0031] The display **104** provides an output for the image capture device **100**. For example, the display **104** may be a liquid crystal display, plasma display, a light emitting diode (LED) display, or so on. The display **104** may display images captured by the image capture device, may function as a viewfinder and display images that may be within a field of view of the image capture device. Furthermore, the display **104** may also display outputs of the image capture device **100**, such as a graphical user interface, application interfaces, and so on.

[0032] The display **104** may also function as an input device in addition to displaying output from the image capture device **100**. For example, the display **104** may include capacitive touch sensors, infrared touch sensors, or the like that may track a user's touch on the display **104**. In these embodiments, a user may press on the display **104** in order to provide input to the image capture device **100**.

[0033] The image capture device **100** may include one or more input mechanisms **112**, **114**. The input mechanisms

112, 114 may be positioned substantially anywhere on the image capture device **100** and provide a mechanism for a user to communicate an input to the image capture device **100**. For example, a user may press down on a first input mechanism **112** to indicate that he or she wishes to capture an image of a scene. In another example, the user may select a second input mechanism **114** to provide input to a graphical user interface, an application or the like.

[0034] The input port **110** may provide an input for the image capture device **100**. The input port **110** may be configured to receive substantially any type of connector, such as but not limited to, a universal serial bus (USB) connector, a trip ring sleeve connector, a micro-USB connector, and so on. There may be multiple input ports **110** spaced around the image capture device **100**. For example, a first input port **110** may be configured to receive a charging cable and a second input port **110** may be configured to receive a trip ring sleeve or other audio connector.

[0035] The image capture device **100** may also include one or more cameras **106, 116**. The cameras **106, 116** may be positioned substantially anywhere on the image capture device **100**; and there may be one or more cameras **106, 116** on each device **100**. The cameras **106, 116** capture light from an image. FIG. 3 is a cross-sectional view of a first camera **106** in FIG. 1A, taken along line 3-3 in FIG. 1A. However, it should be noted that the cameras **106, 116** may be substantially similar to each other. That said, with reference to FIG. 3, each camera **106, 116** may include a lens **122** in optical communication with an image sensor **124**. The lens **122** may be spaced apart from a top surface of the image sensor **124**, in this manner light transmitted through the lens **122** may encounter the image sensor **124**.

[0036] The lens **122** may be substantially any type of optical device that may transmit and/or refract light. In one example, the lens **122** is in optical communication with the sensor **124**, such the lens **122** may passively transmit light from a field of view (FOV) **126** to the sensor **124**. The lens **122** may include a single optical element or may be a compound lens and include an array of multiple optical elements. In some examples, the lens **122** may be glass or transparent plastic; however, other materials are also possible. The lens **122** may additionally include a curved surface, and may be a convex, bio-convex, plano-convex, concave, bio-concave, and the like. The type of material of the lens as well as the curvature of the lens **122** may be dependent on the desired applications of the system **122**. Furthermore, it should be noted that the lens **122** may be stationary within the image capture device **100**, or the lens **122** may selectively extend and/or rotate within the image capture device **100**.

[0037] The image sensor **124** may be substantially any type of sensor that may capture an image or sense a light pattern. The sensor **124** may be able to capture visible, non-visible, infrared and other wavelengths of light. The sensor **124** may be an image sensor that converts an optical image into an electronic signal. For example, the sensor **124** may be a charged coupled device, complementary metal-oxide-semiconductor (CMOS) sensor, or photographic film. The sensor **124** may be in optical communication or electrical communication with a filter that may filter select light wavelengths, or the sensor **124** itself may be configured to filter select wavelengths, e.g., the sensor may include photodiodes only sensitive to certain wavelengths of light.

[0038] Referring again to FIGS. 1A-2B, the image capture device **100** may also include a light source **108, 118** or strobe.

The light source **108, 118** may be substantially any type of device that may produce light, such as but not limited to, a LED, light bulb, or a flash tube or other electrical arc device (e.g., xenon strobe). The light source **108, 118** selectively illuminates a scene or parts of a scene within the FOV **126** of the lens **122**. The light sources **108, 118** may be positioned near the lens **122**; however, in other embodiments, the light source **108, 118** may be spaced apart from the lens **122**. That is, the light source **108** may be a separate attachment for the image capture device **100** such as a detached flash attachment (see, e.g., FIGS. 11A and 11B).

[0039] The image capture device **100** may also include additional components for processing images and communicating with additional devices. FIG. 4 is a block diagram illustrating select components of the image capture device **100**. The image capture device **100** may also include a communication mechanism **128** or network/communication interface, a processor **130**, and memory **134**. Additionally, select components of the image capture device **100** may be in communication via one or more system buses **132**.

[0040] The communication mechanism **128** may receive and transmit various electrical signals. The communication mechanism **128** may be used to send and receive data from secondary devices, as discussed in more detail below with respect to FIG. 5. Additionally, the communication mechanism **128** may be used to place phone calls from the image capture device **100**, may be used to receive data from a network, or may be used to send and transmit electronic signals via a wireless or wired connection (e.g., Internet, WiFi, radio waves, Bluetooth, or Ethernet). In one embodiment, the communication mechanism **128** may include a transmitter in communication with the processor **130** to send data to other devices and a receiver configured to receive signals from other devices.

[0041] The processor **130** may control operation of the image capture device **100** and its various components. The processor **130** may be in communication with the display **104**, the communication mechanism **128**, the memory **134**, and may activate and/or receive input from the image sensor **124** as necessary or desired. The processor **130** may be any electronic device capable of processing, receiving, and/or transmitting instructions. For example, the processor **130** may be a microprocessor or a microcomputer. Furthermore, the processor **130** may also adjust settings on the image sensor **124**, adjust an output of the captured image on the display **104**, may adjust a timing signal of the light source **108, 118**, analyze images, and so on.

Illumination System

[0042] The image capture device **100** may provide signals and/or may control a series of secondary devices in order to illuminate a scene within the FOV **126**. FIG. 5 is a top plan view of a diagram illustrating an illumination system **200** utilizing the image capture device **100**. The system **200** may include the image capture device **100** and one or more secondary devices **202A, 202B, 202C**. The image capture device **100** may function as a master device and may control or provide signals relating to certain aspects of the secondary devices **202A-202C**. Thus, the secondary devices **202A-202C** may be slave devices to the image capture device **100**. In one example, the image capture device **100** may control a light source of each secondary device **202A-202C** to provide a desired illumination of the scene.

[0043] In some embodiments the secondary devices 202A-202C may be substantially the same as the image capture device 100. For example, the secondary devices 202A-202C may be smart phones, tablet computers, mobile electronic devices, digital cameras, and the like. In these embodiments, the “master” device and the “slaves” or secondary devices may be chosen based on something other than the components of the each device, e.g., a position of each device with respect to a scene, user preference, and so on.

[0044] However, in other embodiments, the secondary devices 202A-202C may be different from the image capture device 100. For example, the secondary devices 202A-202C may be single light sources, such as a xenon or other type of light strobe. FIG. 6 is a block diagram of an example secondary device 202. Each secondary device 202 may include a light source 208, a processor 230, and a communication mechanism 228. Each of the illustrated components may be substantially the same as the corresponding components of the image capture device 100. Alternatively, in some embodiments, the light source 208 of the secondary devices 202A-202C may produce a more intense light than light source 108 in the image capture device 100. For example, the light source 208 of the secondary devices 202A-202C may be a xenon strobe light whereas the light source 108 for the image capture device 100 may be a LED. Similarly, the processor 230 of the secondary device 202 may have reduced capabilities as compared with the processor 130, this may allow the secondary devices 202A-202C to use less power as compared with the image capture device 100.

[0045] Returning now to FIG. 5, the system 200 may provide enhanced illumination of a scene within the FOV 126 of the image capture device 100. The image capture device 100 may initiate control of the secondary devices 202A-202C. For example, the image capture device 100 and the secondary devices 202A-202C may each have an illumination application and the user may select a master device, that becomes the image capture device 100, and one or more slave devices that become the secondary devices 202A-202C.

[0046] Once the image capture device 100 and secondary devices 202A-202C are selected, the secondary devices 202A-202C may be tied or paired with the image capture device 100 and optionally the other secondary devices 202A-202C. In one embodiment, the secondary devices 202A-202C may include a program or application that may be activated to provide a connection to the image capture device 100. In this embodiment, the secondary devices 202A-202C may include the same application or program as the image capture device 100, but may have been selected as the “slave” devices. The secondary devices 202A-202C may be tied to the image capture device 100 when the program or application is activated on each particular device 202A-202C.

[0047] In another embodiment, the secondary devices 202A-202C may receive a coded control signal to set them into a “slave” mode. In this embodiment, the secondary devices 202A-202C may be configured to first require a user input prior to accepting such control signals or messages. The slave mode could be built into an operating system of the devices 202A-202C or may be built into a program or application running on the devices 202A-202C.

[0048] In yet another embodiment, the image capture device 100 and the secondary devices 202A-202C may be paired together through a protocol such as Bluetooth or across network such as WiFi, such that secondary devices 202A-202C may be associated with and controlled by the image

capture device 100. In this embodiment, the secondary devices 202A-202C and the image capture device 100 may share a link key, control word, password, and so on to allow them to communicate to each other, as well as to allow the image capture device 100 to function as a master for the secondary devices 202A-202C.

[0049] Once the secondary devices 202A-202C are paired with the image capture device 100, the image capture device 100 may transmit and receive commands and/or other signals to and from the secondary devices 202A-202C. In one embodiment, the image capture device 100 may provide controls for activating the light source 208 of each secondary device 202A-202C. For example, the image capture device 100 may determine the activation time, the activation duration, the light intensity, and the like of the light source 208 for each particular secondary device 202A-202C.

[0050] Furthermore, the image capture device 100 may also transmit signals that may cause the secondary devices 202A-202C to display a certain message. In embodiments where the secondary devices 202A-202C are mobile electronic devices, the image capture device 100 may transmit instructions for a user supporting the device. For example, if a particular secondary device 202A-202C is too close to the image capture device 100, the image capture device 100 may transmit directions related to a new position, e.g., move 10 feet away from the image capture device 100.

[0051] In one example, the image capture device 100 may transmit the control signals over the network to each of the secondary devices 202A-202C. Each secondary device 202A-202C may examine the signal to determine if it contains a unique identifier. If the signal contains the unique identifier, the secondary device may determine that it is an intended recipient of the signal and processes it accordingly. In other embodiments, such protocols may be established through the initial contact and transmissions between the image capture device 100 and secondary device(s) 202A-202C.

[0052] In a second example, the image capture device 100 may transmit the control signals to each specific device. In this example, the control signal may not include a specific identifier as it may be sent directly to one or more select secondary devices 202A-202C.

[0053] In a third example, the image capture device 100 may transmit at least one control signal as a light signal. For example, the light source 108 of the image capture device 100 may send a pre-flash sequence of light flashes to indicate to the secondary devices 202A-202C to activate their respective light sources 208. In this example, the secondary devices 202A-202C may include an optical detector or sensor, such as a photodiode, or a camera (if included) in each of these devices 202A-202C. It should also be noted that the image capture device 100 may provide controls to the secondary devices 202A-202C in substantially any other manner and the aforementioned examples are meant to be examples only.

[0054] As shown in FIG. 5, the secondary devices 202A-202C may be positioned around a scene 210 (e.g., a landscape, object(s), person(s)) to be captured by the image capture device 100. As used herein “scene” refers to any background and/or objects within the FOV 126 of the image capture device 100 and “image” refers to a digital representation of the scene. The position of the secondary devices 202A-202C may be determined by one or more users, who may position the secondary devices 202A-202C according to an instruction from the image capture device 100 or their own

wishes. In some embodiments, the secondary devices 202A-202C may relay their relative or actual position and/or angular placement to the image capture device 100. For example, the secondary devices 202A-202C may include one or more accelerometers, gyroscopes, or global positioning devices in order to determine their angle and position.

[0055] The secondary devices 202A-202C provide light to illuminate the scene 210 as well as to counteract or balance out a background light source 214. In this manner, an image captured by the image capture device 100 may have substantially uniform illumination, such that shadows and/or clipping (e.g., light intensity exceeding a display or capture threshold) may be eliminated.

[0056] Furthermore, in some embodiments, the light source 108 of the image capture device 100 may not provide light for the captured image. In these embodiments, the chance that an image of a person or animal including a red-eye reflection may be reduced. This is because the light sources 208 may be positioned off-center from the person or animal as the image is captured by the image capture device 100. Red-eye reflections, as described above, are typically due to light being positioned directly towards an eye of a person or animal and reflecting back off the eye. Also, the light sources 208 of the secondary devices 202A-202C may also be laterally spaced apart from the lens 122 to further enhance the picture quality and reduce red-eye reflections.

[0057] An example method for capturing an image via the illumination system 200 will now be discussed in more detail. FIG. 7 is flow chart of an example method for capturing an image. The method 300 may begin with operation 302 and the image capture device 100 may initiate communication with the secondary devices 202A-202C. For example, as previously described above, the secondary devices 202A-202C and the image capture device 100 may pair with one another or otherwise provide a communication mechanism so that the image capture device 100 may provide at least one control signal to the secondary devices 202A-202C. In some embodiments, the relationship may be initiated with each device 100, 202A-202C independently. That is, a user may initiate an application on each device.

[0058] After a relationship between the image capture device 100 and the secondary devices 202A-202C has been established, the method 300 may proceed to operation 304. During operation 304, the image capture device 100 may synchronize the secondary devices 202A-202C. For example, an internal clock for the image capture device 100 may be synchronized with an internal clock of the secondary devices 202A-202C, e.g., via reference broadcast synchronization, a protocol such as IEEE 1488, network time protocol, and so on.

[0059] In another example, the image capture device 100 may provide a pre-flash sequence in order to synchronize the secondary devices 202A-202C. For example, the light source 108 may emit a light flash prior to capturing the image. The secondary devices 202A-202C may detect the light flash (through a light sensor) and prepare to initiate their respective light sources 208, which may be substantially instantaneously after detecting the light flash.

[0060] Once the secondary devices 202A-202C are synchronized with the image capture device 100, the method 300 may proceed to operation 306. In operation 306, the secondary devices 202A-202C activate their respective light sources 208. Optionally, the image capture device 100 may also activate its light source 108. The activation of each light source

108, 208 may depend on the device, but generally may include emitting a flash of light, or otherwise providing illumination.

[0061] As the light sources 108, 208 are activating the method 300 proceeds to operation 308 and the image capture device 100 captures an image of the scene 210. In one embodiment, light from the scene 210 (including the background light 214, if any) and the light from the secondary devices 202A-202C is transmitted through the lens 122. The light is then captured by the image sensor 124 and may be converted into an electrical signal.

[0062] The illumination system 200 and the image capture method 300 may increase the quality of images captured by the image capturing device 100. This is because the secondary devices 202A-202C may be laterally separated from the image capture device 100, which may reduce the likelihood of a person or animal within the scene from having a red-eye reflection in the captured image. Additionally, the secondary devices 202A-202C provide light sources 208 at different distances and options from the image capture device 100, allowing light from each secondary device 202A-202C to fill in gaps in each other devices 202A-202C beam pattern, as well as extend the lit-range that may be captured by the image capture device 100.

[0063] Furthermore, in embodiments where the image capture device 100 may transmit signals to the secondary devices 202A-202C via an electronic signal, the light sources 208 may be substantially prevented from firing prematurely. By contrast, conventional flash strobes that may be optically triggered maybe triggered accidentally. For example, many photographs use optically triggered strobes that may trigger in response to another signal, e.g., a second camera, lightning, etc.

Adjusting the Light Intensity and Duration

[0064] The illumination system 200, as shown in FIG. 5, may be used to vary the light intensity, overall image exposure, and/or light positioning for an image captured by the image capture device 100. As discussed above, the image capture device 100 may provide more than one control signal to the secondary devices 202A-202C. The additional control signals may vary the intensity, timing, and/or directions with to move a location of the light sources 208.

[0065] In one example, the image capture device 100 may display a graphical user interface (GUI) on the display 104 so that a user can selectively adjust the illumination and/or timing of the light sources 208 of the secondary devices 202A-202C. FIG. 8 is a front plan view of the image capture device 100 illustrating an example GUI 240. The GUI 240 may include an image 248 of the scene 210, a control icon 242, a controller 242, as well as a secondary device indicator 246A, 246B, 246C for each secondary device 202A-202C in communication with the image capture device 100. It should be noted that the GUI 240 illustrated in FIG. 8 is one example only, and other displays and controllers are envisioned.

[0066] The image 248 of the scene 210 displayed on the GUI 240 may be an actual image captured by the image sensor 124 or a sample image that may be captured by the image sensor 124. For example, the captured image 248 may be a previously taken photograph or may be a view of a sample photograph, e.g., as viewed by the lens 122 prior to actually capturing the image. Accordingly, the user may adjust the light sources 208 to effect a new image of the scene 210. In some embodiments, the GUI 240 may be displayed on

the display **104** of the image capture device **100**, on one or more of the secondary devices **202A-202C**, and/or on another computing device (e.g., laptop, desktop) in communication with the image capture device **100**.

[0067] The GUI **240** may also include the control icon **242** and controller **244**. The control icon **242** may be represented as substantially any type of icon, and in one embodiment as shown in FIG. **8** may be a bar. The controller **244** may be moved with respect to the icon **242** to adjust a particular setting. For example, the control icon **242** may correspond to an intensity of a particular light source (e.g., light sources **108**, **208**), and as a user manipulates the controller **244** the intensity level for the light source may vary. In this example, a first end of the control icon **242** may be a high intensity and a second end of the control icon **242** may be a low intensity, and depending on the placement of the controller **244**, the intensity level for the particular light source is varied.

[0068] In some embodiments, as the controller **244** is moved, the displayed image **248** may adjust correspondingly. For example, as the intensity of the light source **208** for a particular secondary device **202A-202C** is increased, the brightness of the portions of the image illuminated by that secondary device **202A-202C** may be increased. In this manner, the user may be able to see how the adjustment may affect the eventually captured image. This may allow the user to better be able to determine how to adjust a particular light source in order to achieve a desired image.

[0069] The GUI **240** also may include an indicator **246A-246C** for each secondary device **202A-202C** and/or the image capture device **100**. In this manner, the user may select the particular device in which to adjust the light source. For example, the user may select the first indicator **246A** which may correspond to the first secondary device **202A** and as the user moves the controller **244** in a particular manner, the intensity of the light source **208** of the first secondary device **202A** may be adjusted accordingly. After the user has selected completed adjusting the particular device, the image capture device **100** may transmit a control signal to the particular secondary device **202A-202C** with the new control information. In another example, the image capture device **100** may transmit all of the control signals or information simultaneously to each of the secondary devices **202A-202C**.

[0070] Furthermore, the GUI **240** may also display relative distance instructions with respect to the position of the secondary devices **202A-202C**, as well as an example image of the scene as each secondary device **202A-202C** is positioned in a different location. For example, the image capture device **100** may receive positioning data for each secondary device **202A-202C**. The positioning data may correspond to a location of the secondary device **202A-202C** with respect to the scene **210** or the image capture device **100** and may include an angle of the secondary device **202A-202C**. Thus, a user may be able to not only determine how the intensity of the light sources **208** may affect a captured image of the scene, but also how the positions of each secondary device **202A-202C** may affect the captured image.

[0071] It should be noted that the GUI **240** may present controls for substantially any type of parameter of the image, image capture device **100**, or secondary devices **202A-202C**. For example, the user may be able to control an exposure length of light through the lens **122** of the image capture device **100**, a color of a particular light source (e.g., the

devices may include multiple colored lights), the timing of the activation of a particular light source, a color filter for the image sensor **124**, and so on.

[0072] In addition to the GUI **240**, the image capture device **100** or another device (e.g., laptop) may be used to adjust aspects of a captured image. An example method for adjusting the illumination and other image characteristics for the illumination system **200** will now be discussed. FIG. **9** is a flow chart illustrating an example method for adjusting aspects of a captured image. The method **320** may begin with operation **322** and the image capture device **100** may initiate a master-slave relationship with the secondary devices **202A-202C**. As discussed above with respect to FIG. **5**, this type of relationship allows the image capture device **100** to transmit control signals to the secondary devices **202A-202C**. Additionally, the relationship may also allow the secondary devices **202A-202C** to send signals to the image capture device **100** as well.

[0073] Once the master-slave relationship is initiated, the secondary devices **202A-202C** may respond to signals from the image capture device **100**. The method **320** may then proceed to operation **324** and the light sources **208** (and optionally light source **108**) may be activated. As described in operation **306** in FIG. **7**, the image capture device **100** may transmit a signal to activate the light sources **208** of the secondary devices **202A-202C** and optionally may activate its own light source **108**.

[0074] As the light sources **108**, **208** are activated, the method **320** may proceed to operation **326** and the image capture device **326** may capture one or more test images. For example, in one embodiment, a one or more images may be captured by the image capture device **100** with the light sources **208** of the secondary devices **202A-202C** illuminating the scene at varying intensities and/or times. This generally allows the image capture device **100** to capture images of the scene **210** with each secondary device **202A-202C** activating its light source **208** independently and at different intensities. In another example, the image capture device **100** may capture images of the scene **210** with each of the secondary devices **202A-202C** activating its light source **208** at the same time, but with varying intensities. The test images are captured by the image sensor **124** and may be evaluated by the user or the image capture device **100** to determine if certain parameters or settings should be adjusted, as described in more detail below.

[0075] After operation **326**, the method **320** may proceed to operation **328** and the image capture device **100** may display an option permitting the user to adjust the lighting for the scene **210**. Alternatively, as described below in more detail with respect to operation **330**, the image capture device **100** may evaluate the image itself to determine if the lighting or other settings should be adjusted. Accordingly, either the user or the image capture device **100** may determine whether the image should be adjusted. If the illumination of the scene **210** (and thus a captured image) is not to be adjusted, the method **320** may proceed to the end of method **320** and the test image may be retained as the "final" image. In other words, the test image may be stored in the memory **134** or an option may be presented to the user to store the test image in the memory **134**. Alternatively, if the illumination is not to be adjusted, the method **320** may proceed to operation **348** and a new image may be captured. This may allow the test images to be sepa-

rate from the captured images, thus the test images may be locked out from adjustment by a user, have a reduced data amount, or so on.

[0076] If the illumination or another parameter of the scene 210 is to be adjusted in operation 328, the method 320 may proceed to operation 330. In operation 330, the image capture device 100 may determine whether the adjustments will be done automatically or by the user. For example, the image capture device 100 may present an option to the user to determine whether he or she would like to manually adjust the scene illumination or whether he or she may wish to have the image capture device 100 adjust the scene illumination. In another example, the image capture device 100 may have a certain setting for a particular application or user that may determine whether the image capture device 100 should do the adjustments or whether the user will be doing the adjustments.

[0077] If the user elects to make adjustments manually, the method 320 may proceed to operation 332 and the image capture device 100 may display the GUI 240. As the GUI 240 is displayed, the image capture device 100 may receive user input adjusting the illumination in the scene 210. For example, with reference to FIG. 8, the user may physically manipulate the controller 244 (e.g., if the device 100 includes an input mechanism), or may manipulate the controller 244 through the input mechanisms 112, 114. Similarly, the user may also determine which secondary device 202A-202C light source 208 will be manipulated, e.g., by selecting a particular indicator 246A-202C. Further, the user may physically change the position of the secondary devices 202AA-202C with respect to the scene 210.

[0078] It should be noted that, in some embodiments, the image capture device 100 may provide the user with assistance in adjusting the illumination of the scene 210. Referring briefly to FIG. 8, certain aspects of the captured image 248 on the GUI 240 may illuminate, change colors, move, or provide another type of indicator if a position or intensity of a particular light source 208 for a secondary device 202A-202C is positioned ineffectively (as determined by the processor 130). This may provide the user additional information when making changes to the location and/or intensity of the secondary devices 202A-202C. In some embodiments, the device 100 may perform a series of preprogrammed operations to cycle through lighting schemes provided by the secondary devices 202A-202C and show the user the image to be captured under each lighting scheme. The user may then select a particular test image from amongst the various displayed images. Once the user selection is complete, the image capture device 100 may adjust the flash map of each light source 208 accordingly, as described below.

[0079] Referring again to FIG. 9, if the adjustments are to be done by the image capture device 100, the method 320 may proceed to operation 336. In operation 336 the processor 130 may analyze the one or more test images to determine and/or extract the background exposure. The background exposure may include background light sources 214, such as a lamp, sun, television, or the like. The background exposure may be determined by taking a test image in operation 324 prior to activating any of the system 200 light sources or may be determined by analyzing the various test images taken in operation 324 to extract the background image. For example, in each test image the intensity and duration of each light

source 208 may be known, so the background light 214 may be determined by an analysis and comparison of various test images.

[0080] Once the background exposure is determined in operation 336, the method 320 may proceed to operation 338. In operation 338 the image capture device 100 may determine one or more flash or strobe maps or images. The flash maps may provide data with respect to scene 210 and the system 200 regarding how each particular secondary device 202A-202C may affect the overall captured image. In other words, when the light source 208 of a particular secondary device 202A-202C is activated at a certain intensity, the flash map may determine how it affects the overall captured image of the scene 210. Also, the image capture device 100 may receive feedback from each secondary device 202A-202C regarding its position and/or angle. In this manner, the image capture device 100 can better determine the flash map for each particular secondary device 202A-202C based on position, timing, intensity, and/or angle of the light source 208 for each device 202A-202C.

[0081] In one embodiment, multiple test images at multiple intensities may be captured by the image capture device 100 in order to create a high dynamic range flash map. It should be noted that in some embodiments, the test images may be stored at a lower resolution or smaller data file in the memory 134. This may allow the image capture device 100 to utilize the data in each test image, without overly burdening the memory 134. However, in other embodiments, the test images and flash maps may be stored as normal images within the memory 134.

[0082] After the flash map(s) are determined, the method 320 may proceed to operation 340 and the image capture device 100 may calculate and adjust the light source intensity and timing. For example, the image capture device 100 may utilize the flash map to determine how each particular secondary device 202A-202C may affect the overall captured image. Then, the processor 130 may adjust the light sources 208 for each secondary device 202A-202C (and optionally the light source 108 of the image capture device 100), in accordance with a previous user setting, based on a uniform illumination analysis, or the like.

[0083] In one example, the image capture device 100 may adjust the light sources 208 and/or position (by providing positioning instructions) of the secondary devices 202A-202C using heuristics such as maximizing overall brightness of the captured image while avoiding clipping, in order to select the proper adjustments for the system 200. "Clipping," as used herein, generally refers to when an intensity in a certain area of an image falls outside the minimum and maximum intensity which can be represented by the image sensor 124.

[0084] For example, the processor 130 may divide the captured test images into a series of quadrants or zones and then may assess the response for each captured test image in each quadrant. The intensity of the light source 208 for each secondary device 202A-202C (and optionally the light source 108) may then be the variables for each image. The processor 130 may then construct one or more linear equations to determine a desired result, e.g., with what settings for each device 202A-202C does the captured image go beyond a max value without clipping some percentage of the pixels.

[0085] In another example, the processor 130 may analyze certain objects within the scene with polarization or other imaging techniques to better determine how the light may

need to be adjusted in order to best capture the scene 210. The aforementioned examples are some examples of a determination process and other determination processes are envisioned. Once the image capture device 100 has determined the desired adjustments for the secondary devices 202A-202C, the method 320 may proceed to operation 342. In operation 342, the image capture device 100 may transfer the desired adjustment data to each of the secondary devices 202A-202C. The image capture device 100 may transfer the data so that each of the secondary devices 202A-202C can make the adjustments on their own, or through the master-slave relationship, the image capture device 100 may adjust the secondary devices 202A-202C itself.

[0086] Further, in some embodiments, the image capture device 100 may display on the GUI 240 or on a display of the secondary devices 202A-202C directions for position data, so that one or more users may move the secondary devices 202A-202C in accordance with the desired scene illumination. In these embodiments, the image capture device 100 may also receive data corresponding the actual position and/or angle of the secondary devices 202A-202C. This may allow the image capture device 100 to dynamically adjust the positioning instructions for the secondary devices 202A-202C. For example, the positioning instructions may provide a green light and direction arrow on a display of each secondary device 202A-202C pointing in a direction the device 202A-202C is to be moved. Then, once the secondary device 202A-202C has reached the correct position, a red light may be displayed. Other indicators are possible as well. For example, the secondary devices 202A-202C could provide spoken directions, other displayed icons, or the like.

[0087] Once the secondary devices 202A-202C have been appropriately adjusted, the method 320 may proceed to operation 344. In operation 344 the image capture device 100 may optionally adjust the time that the exposure time. In other words, the time that the image sensor 124 may be exposed to light transmitted through the lens. For example, in some embodiments, the image capture device 100 may include a shutter covering the image sensor 124 until an image is going to be captured. In operation 344, the image capture device 100 may determine how long the shutter is raised to allow light from the lens 122 to encounter the image sensor 124. The exposure time affects the amount of light that may be transmitted through the lens 122 to the image sensor 124 and may be adjusted based on a preference of the user and/or a desired captured image appearance. Accordingly, the exposure time may be adjusted to control the background light level, the longer the exposure time, the brighter the background light level that may be captured in the image.

[0088] After operation 324 or after operation 334, the method 320 may proceed to operation 346 and the light sources 208 of the secondary devices 202A-202C and optionally, the light source 108 of the image capture device 100, may be activated. As the light sources 208 are activated, the method 320 may proceed to operation 348 and the image capture device 100 may capture an image of the scene 210. Light from the scene 210, as illuminated by the background light 214 and the secondary devices 202A-202C, may be transmitted through the lens 122 and captured by the image sensor 124. Once the image has been captured, the method 320 may return to operation 328 and the user or the image capture device 100 may determine whether the lighting may need to be adjusted again. However, once the desired image has been captured, the method 320 may end.

[0089] The method 320 and the system 200 may provide a number of different captured images. In one example, the range of images captured by the image capture device 100 may be represented by Eq. (1) listed below.

$$t_e * I_0 + a_1 * I_1 + a_2 * I_2 + \dots + a_n * I_n \tag{Eq. (1)}$$

[0090] In Eq. (1), t_e is the exposure period or exposure time, I_0 is the background image or background light, a_i represents the various amplitudes (e.g., intensity) of the light sources 208 of the secondary devices 202A-202C, and I_1 to I_n are the various test images that may be captured in operation 326. Accordingly, as the exposure time and various amplitudes and intensities of the secondary devices 202A-202C are modified, the capture images may be modified. Further, depending on the number of secondary sources 202A-202C, additional image ranges are possible.

[0091] The method 320 also provides a system for controlling and balancing external light sources for capturing an image. Some conventional digital cameras may include an internal xenon strobe or light source. These integrated light sources may generally include a separate photodiode for intensity and exposure control. When the diode signal integrates itself into the desired intensity level of the strobe, the strobe is extinguished. In these types of cameras, the exposure and/or intensity of the strobe cannot be controlled from the captured image as the strobe duration is typically shorter than the frame readout period for the image sensor. By contrast, the system 200 and method 320 as described herein allow the user to view how changes to position and intensity of each light source 208 may affect an image via the image capture device 100. Additionally, the light sources 208 may be digitally or electronically controlled, as opposed to a diode sensing an optical change and thus may be more easily corrected.

[0092] Furthermore, in conventional lighting systems including multiple strobes, the control process may be even more difficult. This is because each individual strobe may have a separate photodiode detector for control, however, the sum of a group of strobes cannot be automatically adjusted. Rather, a user generally has to adjust each strobe intensity manually through a process of trial and error, which depending on the strobes can be laborious and time extensive. By contrast, the illumination system 200 and method 320 allow the image capture device 100 itself to change each of the light sources 208, as well as allow a user to view how changes to certain light sources 208 may appear.

Remote Light Source

[0093] In addition to the secondary devices 202A-202C, or as a secondary device 202A-202C, a remote light source may also be used to illuminate the scene 210. FIG. 10 is a rear perspective view of an embodiment of the image capture device and a remote light source 400 connected thereto. FIG. 11A is a perspective view of a first embodiment of the remote light source 400. FIG. 11B is a front perspective view of a second embodiment of a remote light source 440. The remote light source 400, 440 may include a light source 402, 420 and a connection mechanism 404, 444. The light source 402, 420 may be substantially the same as the light source 108, 208 in the image capture device 100 and the secondary devices 202A-202C, respectively.

[0094] The connection mechanism 404, 444 may be received within an input port 110 of the image capture device 100. For example, as shown in FIG. 11A, the connection mechanism 404 may be a universal serial bus plug. Alterna-

tively or additionally, the connection mechanism 444 may be configured to be received within a wall outlet or other charging apparatus. For example, as shown in FIG. 11B, the connection mechanism 444 may include one or more prongs configured to be received within a wall outlet.

[0095] In certain embodiments, the remote light source 400, 440 may not be connected to the image capture device 100, but may be positioned similar to the secondary devices 202A-202C near the image capture device 100. In other examples, the remote light sources 400, 440 may be connected to the image capture device 100 when providing illumination to the scene 210. However, the remote light source 400, 440 may be positioned on the image capture device 100 spaced apart from the lens 122. Thus, the remote light source 400, 440 may provide illumination with a decreased change of red-eye illumination.

[0096] Further, the remote light source 400, 440 may be integrated or operably associated with a charging cable, data cable, or other type of connector for the image capture device 100. In these embodiments, the remote light source 400, 440 may be easy for a user to have when he or she wishes to take a photograph, as generally people may carry a charger for a specific electronic device when they take the electronic device to different places. On the contrary, a user may not typically remember to bring a removable flash for an electronic device, as he or she may not realize that he or she may want to take a photograph prior to leaving a house or the like.

[0097] The remote light source 400, 440 may be activated directly by the image capture device 100. For example, data may be communicated through the connector mechanism 404, 444. In other embodiments, the remote light source 400, 440 may be activated remotely by the image capture device 100. In these embodiments, the remote light source 400, 440 may receive and/or send signals to the image capture device 100 in order to receive a control signal and/or activate signal.

CONCLUSION

[0098] The foregoing description has broad application. For example, while examples disclosed herein may focus on utilizing a smart phone or mobile computing device, it should be appreciated that the concepts disclosed herein may equally apply to other image capturing devices and light sources. Similarly, although the illumination system may be discussed with respect to activating a series of light sources, the devices and techniques disclosed herein are equally applicable to any type of output. Accordingly, the discussion of any embodiment is meant only to be an example and is not intended to suggest that the scope of the disclosure, including the claims, is limited to these examples.

What is claimed is:

1. A method for capturing an image comprising:
 - initiating a master-slave relationship between an image capture device and an at least one secondary device;
 - remotely activating one of an at least one light source of the at least one secondary device;
 - capturing a test image of a scene illuminated by the at least one light source by the image capture device;
 - analyzing the test image to determine if an illumination of the scene should be adjusted; and
 - if the illumination of the scene is to be adjusted, providing a control signal to the at least one secondary device including at least one of a position instruction, an intensity level, or timing data.

2. The method of claim 1, wherein the image capture device and the at least one secondary device are one of smart phones, digital music players, or computers.

3. The method of claim 1, wherein prior to activating the at least one light source, the method further includes synchronizing a timing mechanism of the image capture device with a timing mechanism of the secondary device.

4. The method of claim 3, wherein the position instruction comprises data corresponding to a new position of the secondary device with respect to the image capture device.

5. The method of claim 1, wherein the image capture device comprises:
 - a lens;
 - an image sensor in optical communication with the lens;
 - wherein

- the image sensor is configured to capture the image of the scene as light from the scene is transmitted through the lens.

6. The method of claim 1, further comprising:
 - remotely activating one of the at least one light source of the at least one secondary device; and
 - capturing a final image of a scene illuminated by the at least one light source by the image capture device.

7. The method of claim 1, wherein the position instruction is displayed on a display of the image capture device or on the at least one secondary device.

8. An electronic device for capturing images comprising:
 - a lens;
 - an image sensor in optical communication with the lens;
 - a processor in communication with the image sensor; and
 - a communication mechanism in communication with the processor and configured to transmit and receive a control signal to one or more secondary devices; wherein the control signal controls at least one aspect of the light source of the one or more secondary devices.

9. The electronic device of claim 8, wherein the at least one aspect includes a activation time for the light source.

10. The electronic device of claim 9, wherein the at least one aspect includes an intensity of the light source.

11. The electronic device of claim 8, wherein the light source illuminates a scene that is captured by the image sensor.

12. The electronic device of claim 8, wherein the one or more secondary devices are one of a smart phone, a digital camera, or a portable computer.

13. The electronic device of claim 8, further comprising a display in communication with the processor and configured to display a graphical user interface.

14. The electronic device of claim 13, wherein the graphical user interface comprises:
 - a control icon correlated to the at least one aspect of the control signal; and
 - an indicator correlated to one of the one or more secondary devices.

15. The electronic device of claim 14, wherein the processor modifies an image of the graphical user interface depending on the control signal and the one or more secondary devices.

16. A method for capturing an image of a scene with an image capture device comprising:
 - initiating a master-slave relationship between the image capture device and an at least one secondary device

- including a remote light source;

remotely activating the remote light source of the secondary device;

capturing a first image of the scene illuminated by the remote light source; and

constructing a flash map corresponding to a scene illumination provided by the remote light source.

17. The method of claim **16**, further comprising:

determining, by analyzing the flash map, if an illumination of the scene should be altered; and

if the illumination should be altered, transmitting one of a positioning instruction, an intensity level, or a timing instruction to the at least one secondary device.

18. The method of claim **17**, further comprising:

remotely initiating the remote light source; and capturing a second image of the scene illuminated by the remote light source.

19. The method of claim **17**, wherein prior to constructing the flash map, receiving a positioning data from the at least one secondary device.

20. The method of claim **16**, wherein remotely initiating the remote light source comprises sending an activation signal to the at least one secondary device.

* * * * *