



US008665236B2

(12) **United States Patent**
Myers

(10) **Patent No.:** **US 8,665,236 B2**
(45) **Date of Patent:** **Mar. 4, 2014**

(54) **ELECTRONIC DEVICE WITH WRAP AROUND DISPLAY**

(75) Inventor: **Scott A. Myers**, San Francisco, CA (US)

(73) Assignee: **Apple Inc.**, Cupertino, CA (US)

(*) Notice: Subject to any disclaimer, the term of this patent is extended or adjusted under 35 U.S.C. 154(b) by 163 days.

(21) Appl. No.: **13/245,646**

(22) Filed: **Sep. 26, 2011**

(65) **Prior Publication Data**

US 2013/0076612 A1 Mar. 28, 2013

(51) **Int. Cl.**
G06F 3/041 (2006.01)

(52) **U.S. Cl.**
USPC **345/173**

(58) **Field of Classification Search**
None
See application file for complete search history.

(56) **References Cited**

U.S. PATENT DOCUMENTS

6,311,076	B1	10/2001	Peuhu et al.	
6,655,788	B1	12/2003	Freeman	
7,724,508	B2	5/2010	Bemelmans et al.	
7,953,462	B2	5/2011	Harry	
8,096,068	B2	1/2012	Van Rens	
2003/0060269	A1*	3/2003	Paulsen et al.	463/20

2007/0115683	A1	5/2007	Park	
2007/0190274	A1	8/2007	Hamaguchi	
2007/0247422	A1	10/2007	Vertegaal	
2008/0146285	A1*	6/2008	Lee et al.	455/566
2008/0212271	A1	9/2008	Misawa	
2009/0019401	A1	1/2009	Park et al.	
2010/0117975	A1*	5/2010	Cho	345/173
2011/0043479	A1	2/2011	Van Aerle et al.	
2011/0095999	A1	4/2011	Hayton	
2011/0148797	A1	6/2011	Huitema et al.	
2011/0261002	A1*	10/2011	Verthein	345/174

FOREIGN PATENT DOCUMENTS

KR	2010-0019164	2/2010
KR	2010-0081161	7/2010
KR	2011-0068169	6/2011
KR	2011-0082941	7/2011
WO	WO 2009131447	A1* 10/2009
WO	WO 2011-114190	9/2011

OTHER PUBLICATIONS

PCT/US2012/056311—International Search Report, mailed Mar. 28, 2013.

* cited by examiner

Primary Examiner — Nicholas Lee

(74) *Attorney, Agent, or Firm* — Womble Carlyle Sandridge & Rice, LLP

(57) **ABSTRACT**

A consumer electronic product includes at least a transparent housing and a flexible display assembly enclosed within the transparent housing. In the described embodiment, the flexible display assembly is configured to present visual content at any portion of the transparent housing.

20 Claims, 8 Drawing Sheets

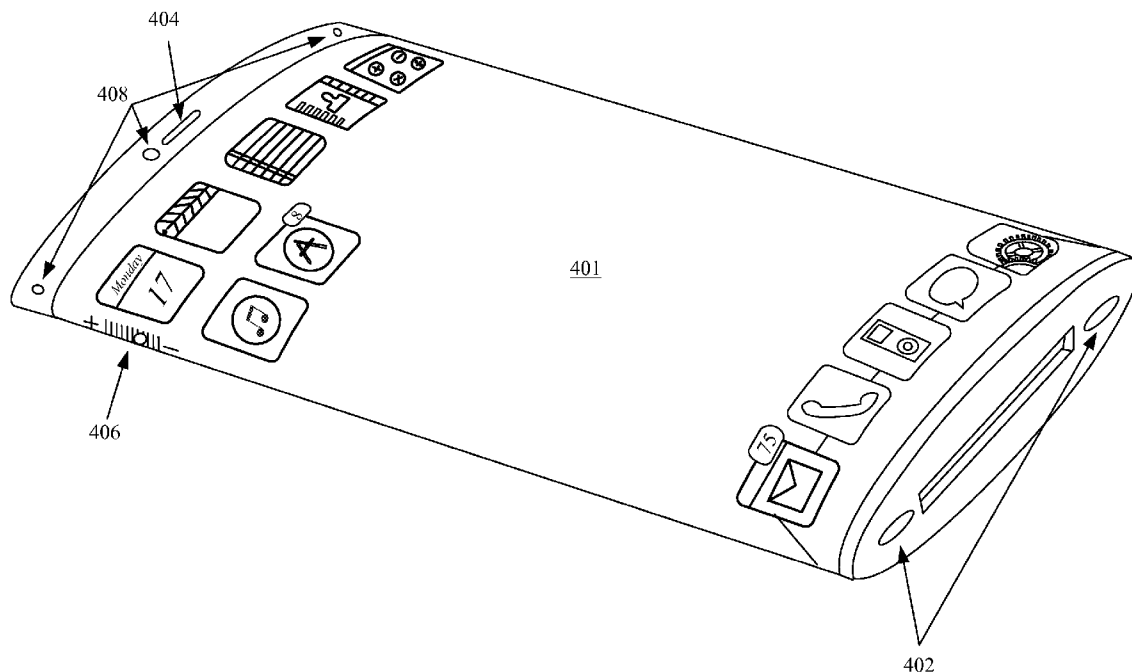

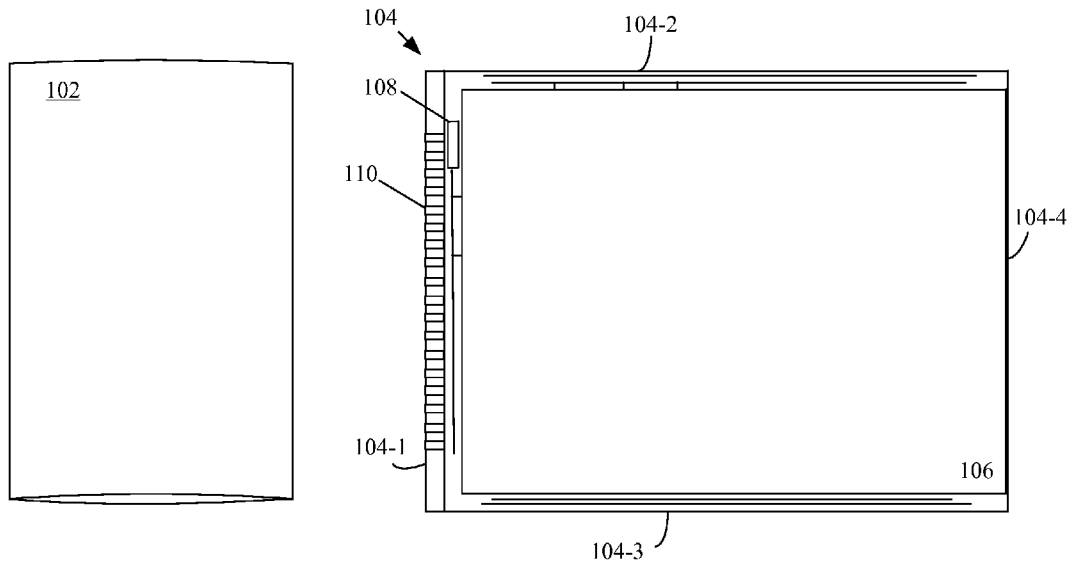

Fig. 1A

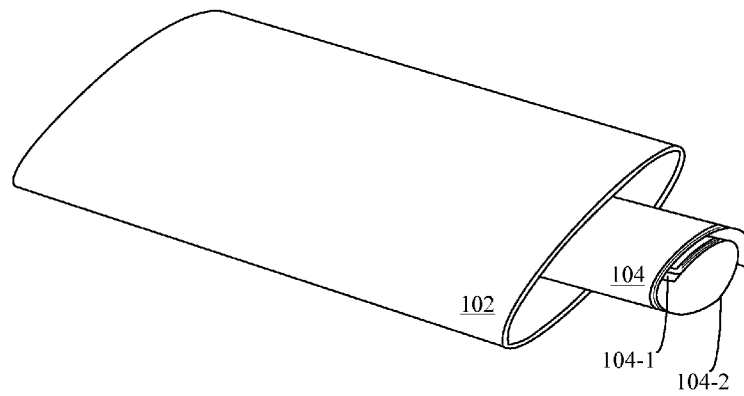

Fig. 1B

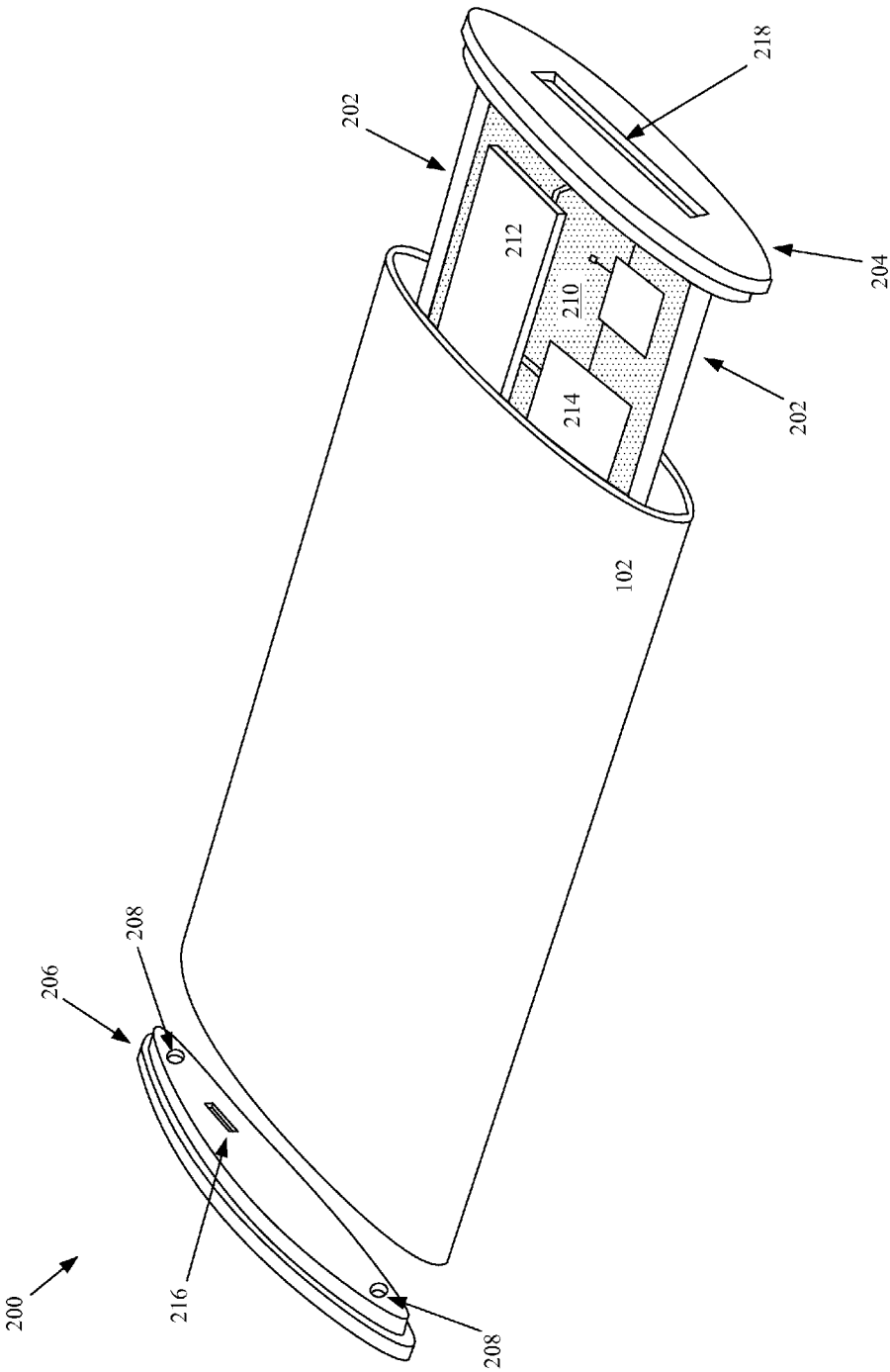

Fig. 2

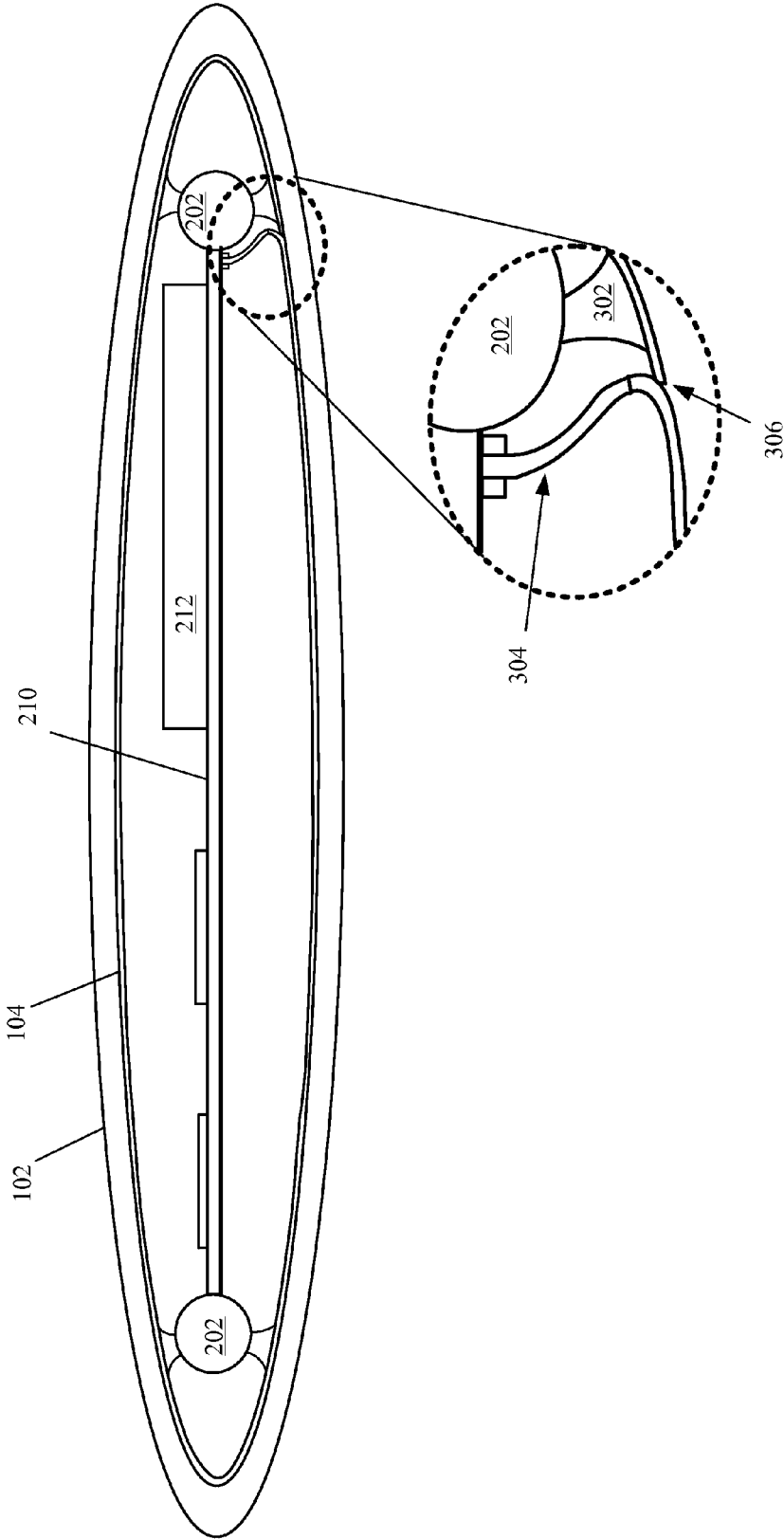

Fig. 3

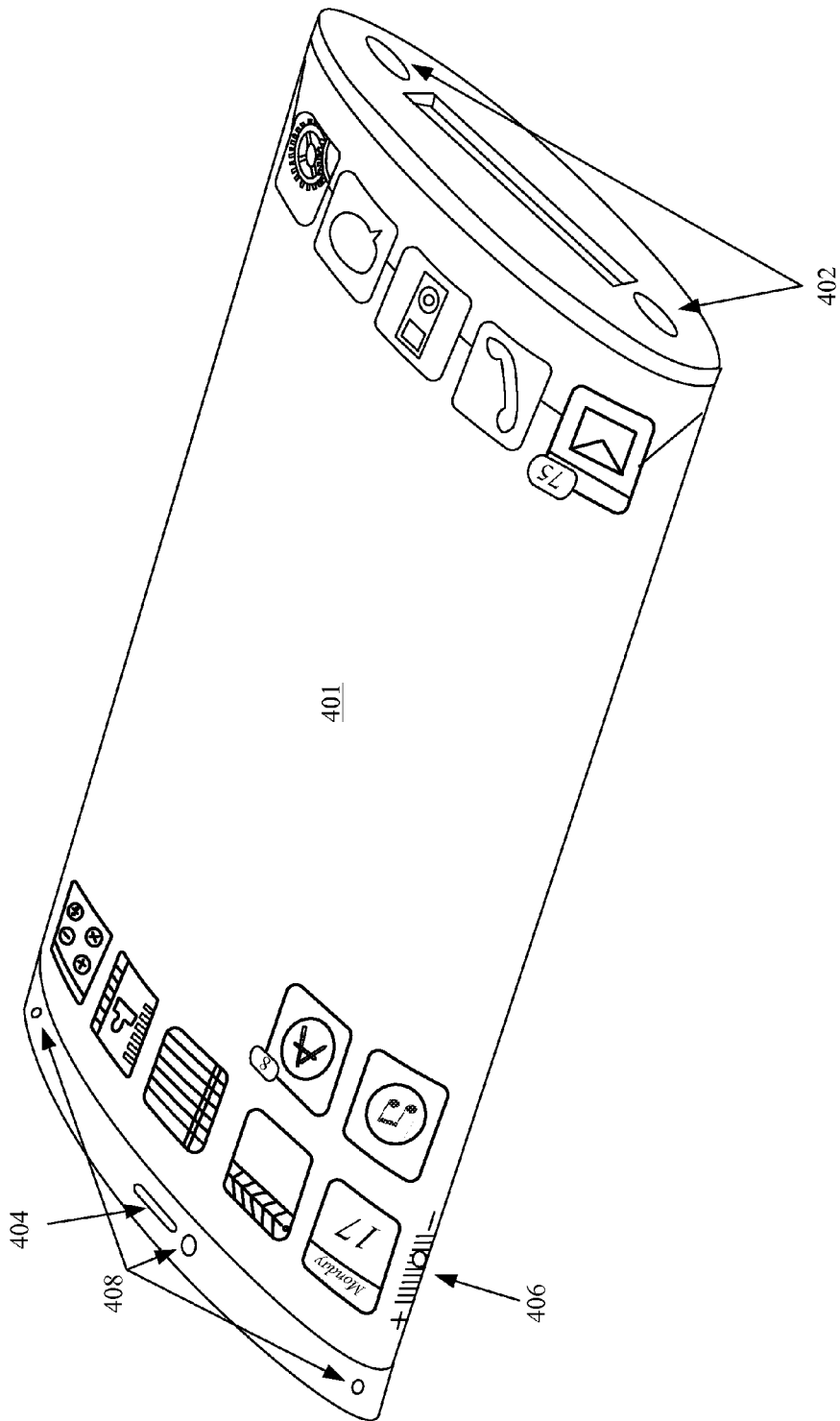

FIG. 4

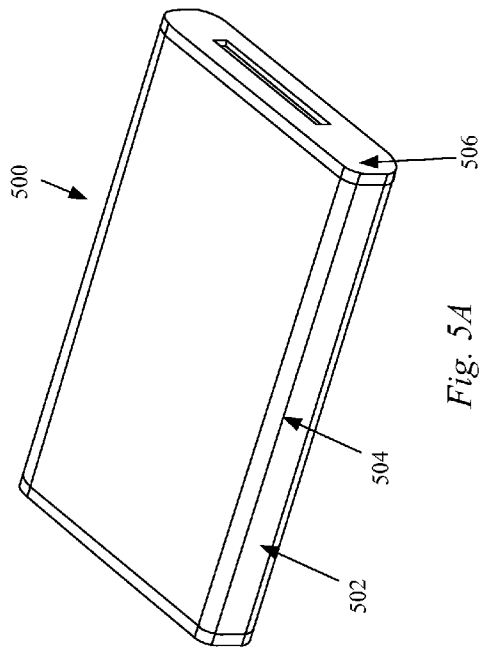

Fig. 5A

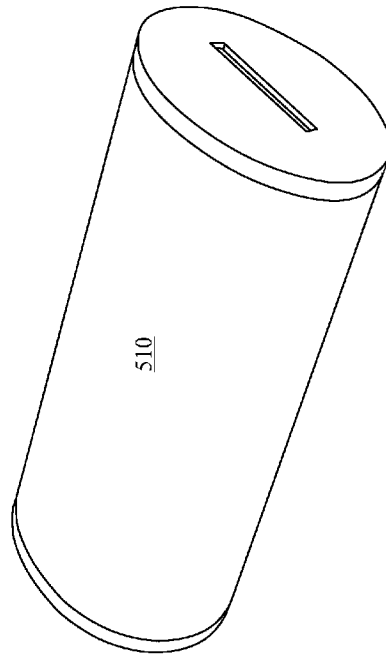

Fig. 5B

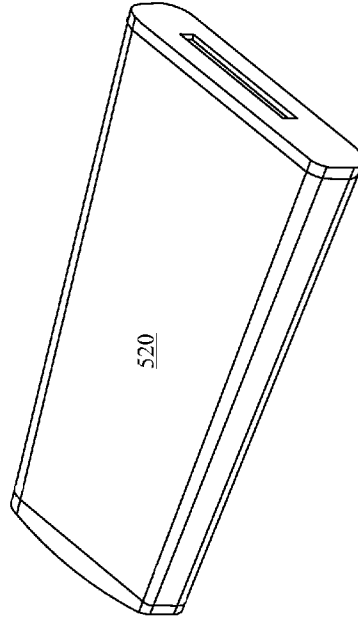

Fig. 5C

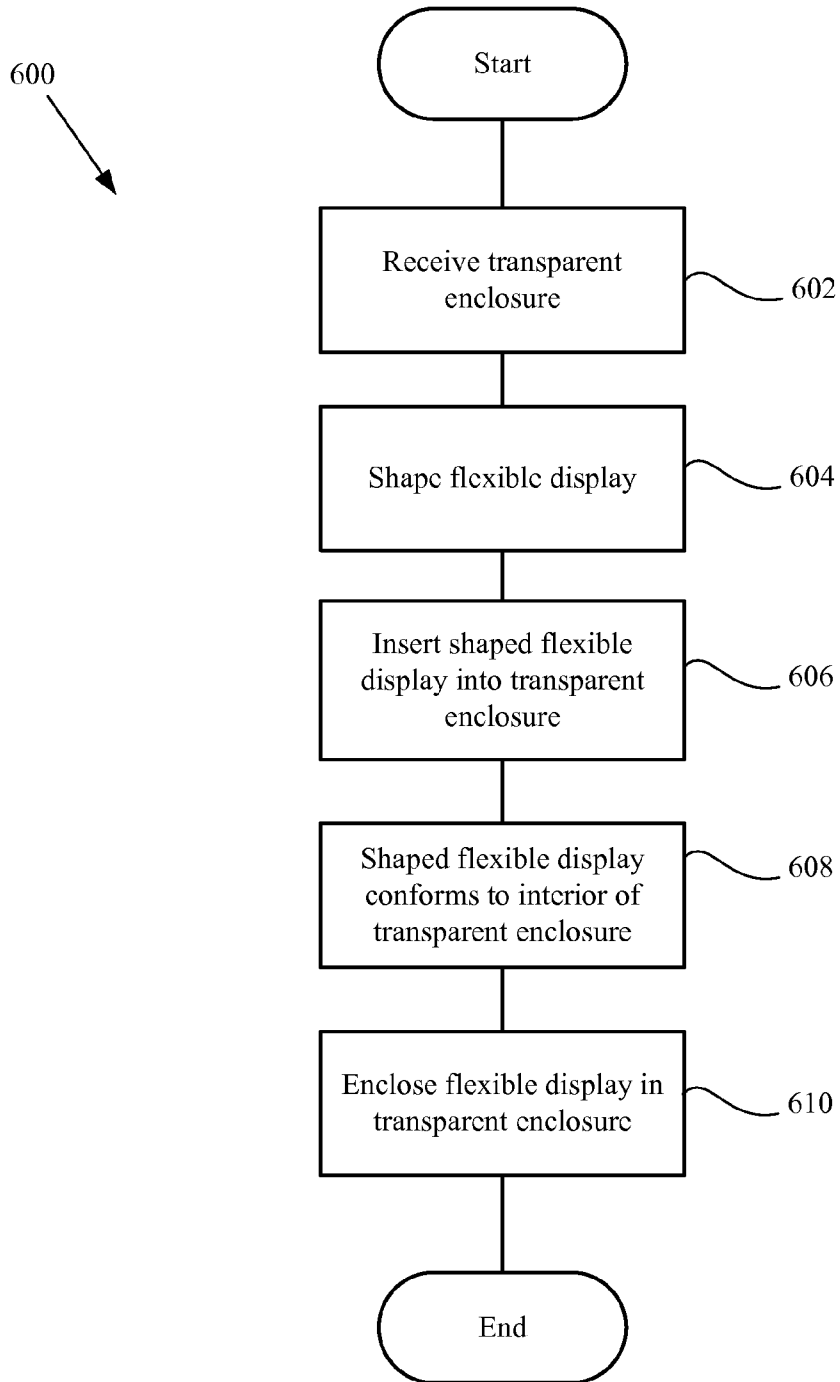

Fig. 6

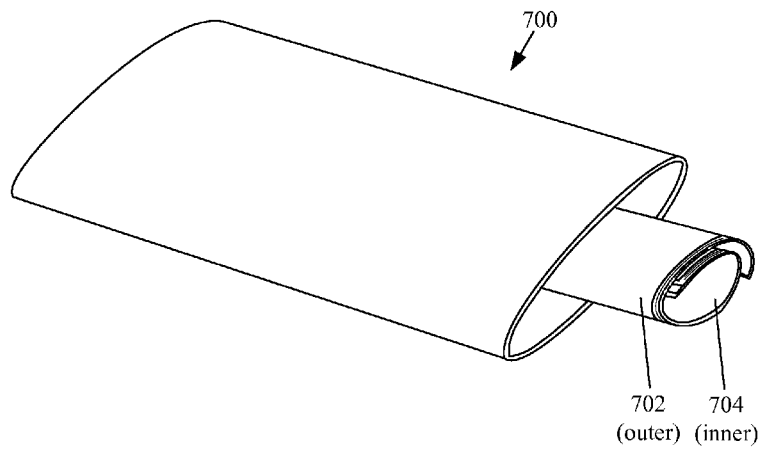

Fig. 7A

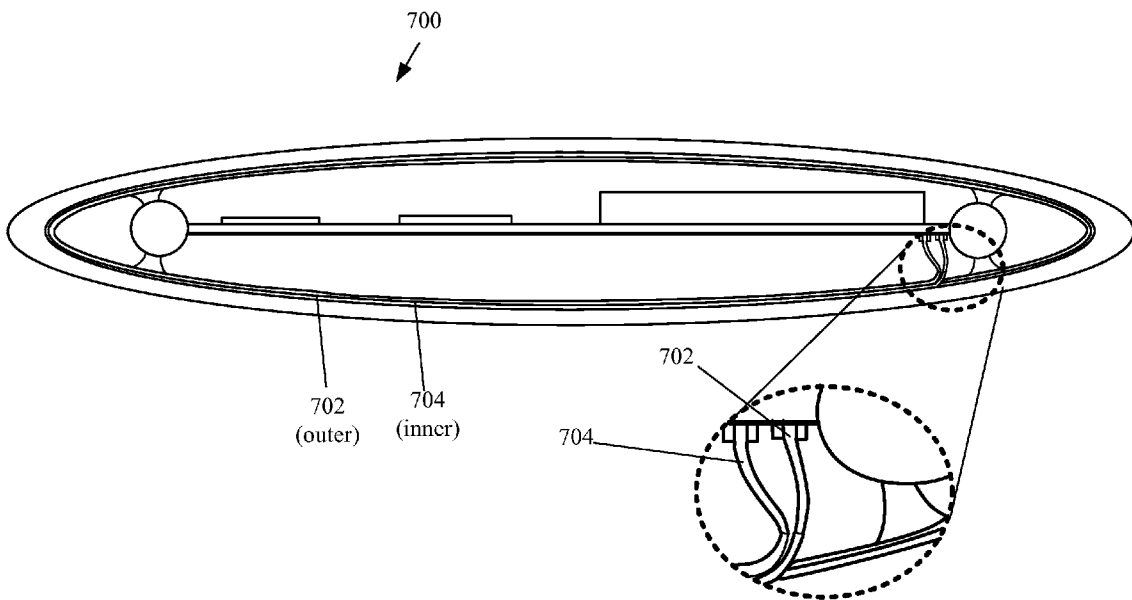

Fig. 7B

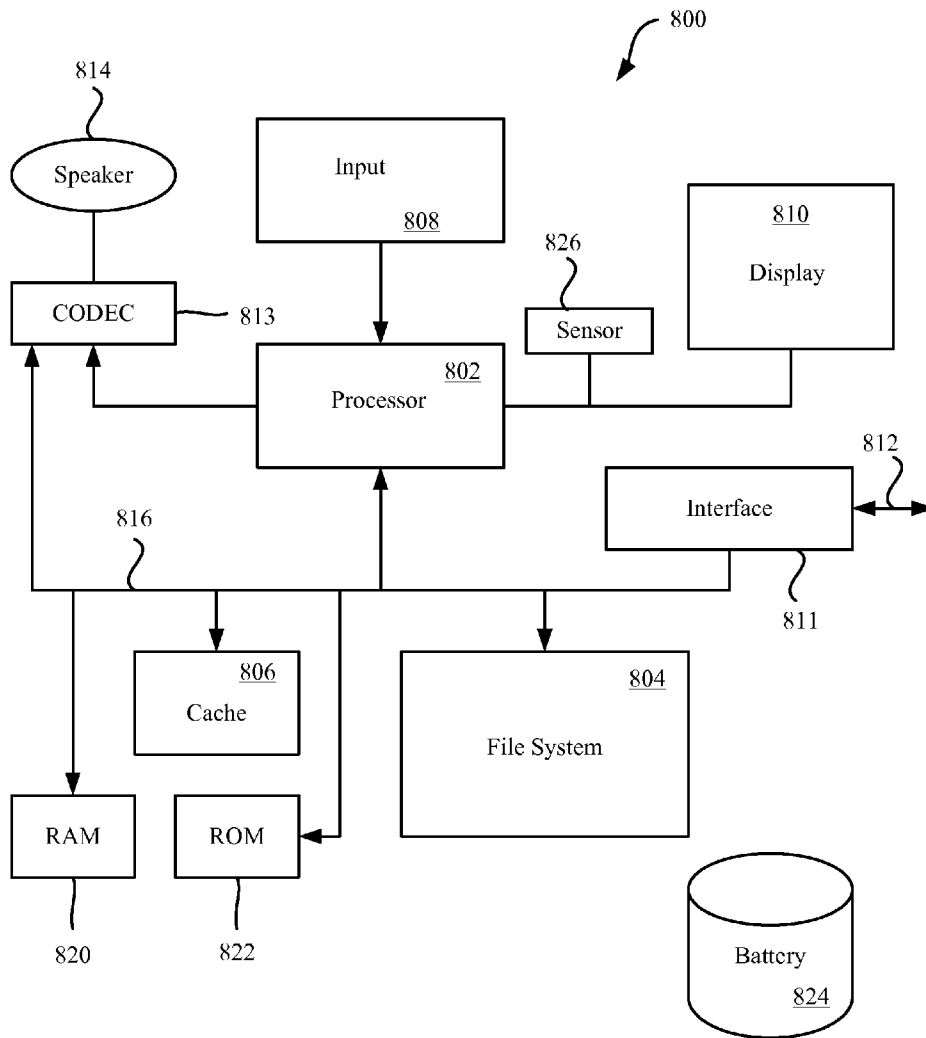

Fig. 8

ELECTRONIC DEVICE WITH WRAP AROUND DISPLAY

BACKGROUND

1. Field of the Described Embodiments

The described embodiments relate generally to portable electronic devices. In particular, expanding the functionality of a portable electronics devices by providing a more efficient mechanism for presenting visual content are disclosed.

2. Related Art

In the last few years the functionality of portable electronic devices has increased exponentially. Further improvements be realized by investigating ways to maximize the utility of unused portions of these devices. Form factor is an interesting area for development given that a large majority of portable electronic devices have settled into a standard form factor; namely a flat planar form factor with a display on one side and an opaque housing which contains the electrical components covering the rear surface of the device. Unfortunately, this popular form factor, leaves the sides and rear surfaces of the device unused or at best configured with buttons and switches with fixed location and functionality. Since many of these buttons and switches have fixed functionality they cannot always be incorporated into third party applications.

Therefore, there exists a need for an improved form factor for portable electronic devices which allows functionality to extend to more than one surface of the device.

SUMMARY OF THE DESCRIBED EMBODIMENTS

This paper describes various embodiments that relate to an apparatus, method, and computer readable medium for creating a portable electronic device with a wraparound display.

In one embodiment, a consumer electronic product is described. The consumer electronic product includes at least a transparent housing and a flexible display assembly enclosed within the transparent housing. In the described embodiment, the flexible display assembly is configured to present visual content at any portion of the transparent housing.

In one aspect of the described embodiment, the consumer electronic product includes a second flexible display assembly. The second display acts to present visual content in cooperation with the flexible display assembly.

In another embodiment, a method for assembly of a multi-display portable electronic device is described. The method is carried out by performing at least the following operations: receiving a transparent enclosure, shaping a flexible display to conform to a cross section of the transparent enclosure, inserting the shaped flexible display into the transparent enclosure.

Subsequent to the inserting, the shaped flexible display returns to an original shape that causes a display portion of the flexible display to press against an interior surface of the transparent enclosure. The method also includes the operation of enclosing the inserted flexible display into the enclosure.

An apparatus for assembly of a multi-display portable electronic device is described. In one embodiment, the apparatus includes at least means for receiving a transparent enclosure, means for shaping a flexible display to conform to a cross section of the transparent enclosure, means for inserting the shaped flexible display into the transparent enclosure. Subsequent to the inserting, the shaped flexible display returns to an original shape that causes a display portion of

the flexible display to press against an interior surface of the transparent enclosure. The apparatus also includes at least means for enclosing the inserted flexible display into the enclosure.

BRIEF DESCRIPTION OF THE DRAWINGS

The described embodiments and the advantages thereof may best be understood by reference to the following description taken in conjunction with the accompanying drawings. These drawings in no way limit any changes in form and detail that may be made to the described embodiments by one skilled in the art without departing from the spirit and scope of the described embodiments.

FIG. 1A shows a representative housing and associated flexible display assembly in an unassembled state.

FIG. 1B shows a flexible display assembly in a rolled up configuration within housing of FIG. 1A in a partially assembled state.

FIG. 2 shows a perspective view of portable electronic device as internal components of portable electronic device 200 are being inserted into transparent housing.

FIG. 3 shows a bottom view of portable electronic device in accordance with the described embodiments.

FIG. 4 shows a perspective view of portable electronic device in operation. Notice how the wrap around display substantially increases the available display area that can be used for display of icons, data, images, video and such.

FIGS. 5A, 5B, and 5C illustrate a variety of additional representative form factors in which the described embodiments can be manufactured.

FIG. 6 shows a flowchart detailing process in accordance with the described embodiments.

FIGS. 7A and 7B shows multiple display portable communication device in accordance with the described embodiments.

FIG. 8 is a block diagram of an electronic device suitable for use with the described embodiments.

DETAILED DESCRIPTION OF REPRESENTATIVE EMBODIMENTS

The presently described embodiments relate generally to media devices. More particularly, a media device having a wrap-around display enclosed within a transparent enclosure is described.

In the following description, numerous specific details are set forth to provide a thorough understanding of the presently described embodiments. It will be apparent, however, to one skilled in the art that the presently described embodiments may be practiced without some or all of these specific details. In other instances, well known process steps have not been described in detail in order to avoid unnecessarily obscuring the presently described embodiments.

The majority of portable electronic device manufacturers utilize a common form factor consisting generally of a flat planar form factor with a single surface dedicated mainly for use as a display surface, while the other surfaces remain largely unused, save for the occasional button or switch. The conventional form factor has been used in devices such as smart phones, tablet devices, and electronic book readers. Although this form factor lends itself to electronic devices that are aesthetically pleasing and easy to handle, the requirement for a planar display and associated circuitry inherently limits the amount of surface area to single surface. More

specifically, the size of the user interface is generally limited to a portion of the device that takes up less than half of the overall device surface area.

In one embodiment, utilizing a flexible display can provide additional viewing area without increasing either the size or shape of the electronic device. For example, a flexible display can be folded in such a way as to form a continuous loop such that images (still or video) can be presented in a wrap-around manner in which the images appear to be presented in a continuous loop. The flexible display can be folded into a tightly wound configuration and placed within an enclosure at least a portion of which is transparent. In some cases, the enclosure can be formed of glass at least a portion of which is made opaque (at least translucent) by the addition of ink or other masking material. In other cases, however, the entire enclosure can be fully transparent in which case the folded flexible display can unwind when placed within the glass enclosure. Once fully unwound, the flexible display can present images at any portion of the glass enclosure.

These and other embodiments are discussed below with reference to FIG. 1-x. However, those skilled in the art will readily appreciate that the detailed description given herein with respect to these figures is for explanatory purposes only and should not be construed as limiting.

FIG. 1A shows housing **102** alongside representative flexible display assembly **104**. Housing **102** can take many forms. For example, housing **102** can be multi-part in which a portion is metallic in nature (such as aluminum) whereas another portion can be formed of optically transparent material such as glass. For the remainder of this discussion, however, housing **102** is considered to be fully formed of transparent (or at least semi-transparent) material such as glass. In this way and without loss of generality, transparent housing **102** may be made of any transparent material such as for example glass, or plastic. The material selected generally depends on many factors including, but not limited to, strength (tensile), density (lightweight), strength to weight ratio, Young's modulus, corrosion resistance, formability, finishing, recyclability, tooling costs, design flexibility, manufacturing costs, manufacturing throughput, reproducibility, and the like. The material selected may also depend on electrical conductivity, thermal conductivity, radio wave and optical transparency, combustibility, toxicity, and the like. The material selected may also depend on aesthetics, including color, surface finish, and weight.

In one particular embodiment, housing **102** can be formed from a glass tube. The glass tube may be formed from an extrusion or extrusion-like process. Some of the reasons for using glass over other materials are that glass is strong, stiff, and radio transparent and therefore a suitable material for an enclosure of an electronic device capable of wireless communications and presenting visual content at any surface thereof. The radio transparency is especially important for wireless hand held devices that include antennas internal to the enclosure. Radio transparency allows the wireless signals to pass through the enclosure and, in some cases, even enhances these transmissions. It will be understood that, although a glass enclosure is capable of wireless communications, the embodiments described herein need not be capable of wireless communication.

Using glass for the fabrication of housing **102** can also provide the portable electronic device with a unique, aesthetically pleasing appearance. To further provide an aesthetically pleasing appearance, the glass can also be coated with an oleophobic coating to reduce finger prints and smudging on the glass. The glass can also be coated with an anti-reflective coating to reduce glare. It will be understood that chemically

strengthened glass can also be scratch resistant. The glass can also be color tinted in a wide variety of colors and can also have a variety of surface finishes including smooth and rough. For example, the glass can be polished to create a smooth (gloss) finish, or a blasting operation can be performed to create a rough or textured (matte) finish. Portions of the glass can also be textured so that the textured surface will disperse light and can be used as light indicator. As discussed in more detail below, the glass material can be formed so that the enclosure can have a seamless or substantially seamless appearance. The seamless enclosure, in addition to being aesthetically pleasing, can provide the added benefit of less contamination and moisture intrusion into the interior of the device.

In some cases, even though housing **102** is fully fabricated from a transparent material such as glass, it may be desirable to obscure at least portions of housing **102** from the view of an end-user. For example, internal components may be visible through housing **102** detracting from the overall look and feel of the electronic product. Therefore, in some cases, portions of housing **102** can be optically obscured. The glass enclosure around the display can be made opaque so the operational components of the device are not visible. One method of rendering portions of housing **102** opaque is to use an ink printing process in those areas where opacity is desired to create a mask. For example, appropriately placed ink can render a masked region that is optically opaque. For example, an area surrounding a display can be masked to provide an emphasis and accentuate visual content presented by the display. It should be noted that in alternative embodiments, portions of housing **102** can be painted or screen printed. Other techniques for achieving opacity in certain areas, such as using a two-layer clad glass.

It should be noted that glass has been used in a wide variety of products, including electronic devices, such as watches, and phones. In these cases, however, the glass materials have not been used as structural components. In most of these cases, the glass materials have been used as cosmetic accoutrements or solely as a screen for a display. It is believed that, up until now, glass materials have never been used as a structural element providing substantially all of the structural frames, walls and main body of a consumer electronic device, and more particularly an enclosure of a portable electronic device, such as a media player or mobile phone.

The glass enclosure also allows a display screen to be positioned underneath and protected by the glass enclosure. The glass material of the enclosure is capable of capacitive sensing so that a touch screen can be used through the glass enclosure. The cross-sectional shape, including both the outer and inner shapes of housing **102** may be widely varied. They may be formed from simple or intricate shapes, whether rectilinear and/or curvilinear. For hand held devices, it is typically preferred to use a shape that better fits the hand (e.g., form fits). By way of example, a rectangle with curved edges or an oval or pill shaped cross section having curvature that more easily receives the hand may be used. It should be noted that the inner cross-sectional shape may be the same or different from the external cross sectional shape of the main body. For example, it may be desirable to have a pill shaped external and a rectangular shaped interior, etc. In addition, although not a requirement, the front surface of the housing **102** may be substantially planar for placement of a display or a user interface that can be incorporated into housing **102** separate from the display.

In this particular embodiment, transparent housing **102** can take the form of an elliptical extrusion. The flexible display assembly **104** can be an active matrix light emitting diode (AMOLED) display manufactured on a polyimide substrate.

5

In addition to being flexible, AMOLED displays allow pixels to be lit up individually, as opposed to conventional LCD technology in which the entire screen is in either an on or an off state. Consequently, an AMOLED screen can display small amounts of text at extremely conservative power levels. This type of display screen typically has an active display area **106** which has supporting circuitry that surrounds at least some of the edges. For example, flexible display assembly **104** has active display area **106** surrounded on three of four edges with supporting circuitry that generally includes display driver chip **108** and sensor flex connector **110** on side **104-1** and additional circuitry and associated connectors on sides **104-2** and **104-3**. It should be noted that with suitable design considerations, remaining side **104-4** can be configured in such a way that only a small unused border sufficiently narrow to be effectively unnoticeable can be provided.

One of the advantages of using a polyimide substrate is that the AMOLED display screen can be heated that allows the AMOLED display screen to be configured into any number of shapes. Moreover, once the heat is removed, the AMOLED display will then “remember” the original shape even if temporarily rolled up or flattened out. In this way, by heating AMOLED display assembly **104** while configured in a shape in accordance with transparent housing **102** AMOLED display assembly **104** easily conforms to the shape of transparent housing **102**. For example, FIG. 1B shows a preheated AMOLED display assembly **104** temporarily rolled up as it is placed into lumen **112** of transparent housing **102**. Once inside transparent housing **102**, AMOLED display assembly **104** can be released resulting in AMOLED display assembly **104** “unwinding” to assume the shape of lumen **112** of transparent housing **102** in such a way that AMOLED display assembly **104** is arrayed against interior surface **114** of transparent housing **102**. In order to secure unwound display assembly **104** to transparent housing **102**, a laminating process can be performed subsequent to the unwinding of AMOLED display assembly **104** to interior surface **114** of transparent housing **102**. For example, an adhesive can be placed between the interior surface **114** and AMOLED display assembly **104** at locations not viewable by an end-user. It should be noted that edges **104-2** and **104-3** of AMOLED display assembly **104** are now positioned at the top and bottom of transparent housing **102**, leaving only edge **104-1** with the connector **110** and display driver chip **108** to be hidden from view. Once AMOLED display assembly **104** is securely attached to the inside surface of transparent housing **102**, the other electrical components can be inserted.

FIG. 2 shows a perspective view of portable electronic device **200** as internal components of portable electronic device **200** are being inserted into transparent housing **102**. An internal frame for portable electronic device **200**, which supports the electrical components, can include two support columns **202**, which are secured by end cap **204** and end cap **206** by way of end cap receivers **208**. End cap **204** and end cap **206** can be made of any suitable rigid material, such as plastic, aluminum, or even steel. Printed circuit board (PCB) **210** can be supported by a rigid framework (not shown) connecting support columns **202**. PCB **210** allows the other supporting electrical components such as battery **212** and processor **214** to drive the operations of portable electronic device **200**. End cap **204** and end cap **206** also include electrical connectors **216** so that components housed within them, such as data connector **218**, and RF antennae (not shown) can cooperate and interact with electrical components disposed on PCB **210**. Once end caps **204** and **206** are secured on either end of transparent housing **102** all the electrical components are enclosed within transparent housing **102**. Support columns

6

202 can be mechanically fastened to end caps **204** and **206** so that the end caps stay firmly in place. In one embodiment, fasteners such as small screws (not shown) can be embedded in at least one of the end caps, allowing for the end cap to be released from support columns **202** when the screws are loosened. This configuration would allow the end caps to be easily removed for maintenance purposes. In another embodiment the removable end cap could also allow users to add end caps with additional functionality. For example, an end cap could be installed that would allow two devices to be connected together and act as one system. This could be as simple as having an end cap with a male data connector designed to attach to data connector **218** of another similar portable electronic device **200**. In yet another embodiment an alternate end cap could have an improved camera or a different set of wireless antennae.

FIG. 3 shows a bottom view of portable electronic device **200** in accordance with the described embodiments. In this view structural support elements **302** are shown attached to support columns **202**. Support elements **302** can help provide structural support to transparent housing **102**. Structural support elements **302** can be deployed after the support columns and electrical components are all connected and in place, thereby providing further support for all the components housed within portable electronic device **200**. In cases where transparent housing **102** is made of a material which requires reinforcement additional supports may be attached to the inner framework so that portable electronic device is truly robust. Also shown in this drawing is the connection between AMOLED display assembly **104** and PCB **210**. The two components are attached by sensor flex **304**, which allows data to pass between the two components. This diagram also shows how the two ends of AMOLED display assembly **104** join together at lap joint **306**. The portion of AMOLED display assembly **104** that extends past the lap joint is the final portion of the border of AMOLED display assembly **104** that is hidden to provide one continuous display that extends around the entire device. If lap joint **306** cannot be made to look seamless it may be desirable to cover lap joint **306** with a thin line of dark paint on the interior of transparent housing **102**. In this the lap joint can be positioned on one edge of the device to further conceal any apparent discontinuity. In situations where a dark paint concealer is used a butt joint could also be used as the cosmetic appearance of the device is less crucial. It should also be noted that although the lap joint is shown on a bottom portion of portable electronic device **200** it can be positioned anywhere along the inside of the device.

FIG. 4 shows a perspective view of portable electronic device **200** in operation. Notice how the wrap around display substantially increases the available display area that can be used for display of icons, data, images, video and such. For example, as shown in FIG. 4, up to five application icons can be presented that span the width of display **401**. Microphones **402** and speaker **404** allow portable electronic device **200** to act as a portable personal communication device, such as a smart phone. Furthermore, virtualization of the physical buttons allows for expanded functionality. For example, volume control **406** can be located at roughly the same position it would be if it were configured as a physical button; however, in this configuration the actual volume setting can be seen at any time (indicated by the circle between the + and - indicators). Additionally, by holding a finger over the volume indicator an action could be triggered expanding the volume control over the entire left side of the device. This would allow a user to make fine adjustments to the volume of portable electronic device **200**. Once the adjustment control is released the control can return to its original size. A hold

switch is another popular function that is often assigned to a physical button. Instead of the hold button a multi touch gesture along one of the sides could instead act as a method of locking and unlocking the hold function. Additional features that can be well suited for portable electronic device 200 include various image capture devices along the lines of cameras 406. It should be noted that since portable electronic device 200 can present visual content in any direction it is important for the portable electronic device 200 to be able to determine a current location of the end-user. In this way, any of cameras 406 can periodically capture an image and using basic facial recognition software, one or more of cameras 406 can be used to track the movement the end user's face in the space around it and as such be able to determine a general direction of the end-user and the field of vision of the end user and adjust the presentation of visual content by display 401 accordingly.

FIGS. 5A, 5B, and 5C illustrate a variety of additional representative form factors in which the described embodiments can be manufactured. For example, FIG. 5A shows embodiment 500 that includes rectangular shaped housing 502. It should be noted that the rounded corners of FIG. 5A permit an end-user's finger to move objects around the corners of the device. In yet another embodiment, transparent housing 502 can be strengthened by the addition of external frame 504. External frame 504 can provide support for corners 506 and provide additional support for portable electronic device 500. FIG. 5B shows embodiment 510 that includes a cylindrically shaped housing 512. In this case orientation sensors such as an accelerometer and facial tracking can be used in maintaining user interface correctly oriented in the visual field of the end user. In FIG. 5C housing 520 can have a tapered shape with a variably sized cross section. In this embodiment, AMOLED display assembly 104 can be manufactured in a non-rectangular shape, allowing the display to conform to the internal surface of housing 520.

FIG. 6 shows a flowchart detailing process 600 in accordance with the described embodiments. Process 600 can be used to assemble a portable communication device having a wrap-around flexible display enclosed within a transparent housing. The portable communication device can further include wireless communication functionality provide an end-user with the option of configuring the portable communication device as a personal communication device along the lines of a smart phone. In any case, process 600 begins at 602 by receiving an enclosure at least a portion of which is transparent. In one embodiment, the enclosure can be fully formed of a transparent material such as glass that can also be used as structural support for the portable communication device. In another embodiment, the enclosure can be a multi-part housing where one portion is formed of structural material such as metal such as aluminum whereas another portion can be formed of transparent material such as glass integrally formed with the metallic housing.

At 604, a flexible display is shaped in such a way as to be inserted into a lumen of the enclosure. For example, when the lumen of the enclosure is circular or circular-like in nature, the flexible display can be wound, or rolled, up into a shape consistent with the shape of the lumen. By rolling up the flexible display into, for example, a cylinder, the rolled up flexible display can be easily inserted into the lumen of the enclosure. Once the rolled up flexible display is within the lumen of the enclosure, the flexible display unwinds, or unrolls, at 606 and conforms to the shape of the lumen and thereby provides a display surface at an interior surface. Next at 608, the enclosure is sealed at either or both ends. For

example, end caps can be attached to the enclosure to complete the assembly of the portable communication device.

In one embodiment as shown in FIGS. 7A and 7B, a second flexible display can be inserted subsequent (or concurrent with) the insertion of the first flexible display. More particularly, FIGS. 7A and 7B shows multiple display portable communication device 700 in accordance with the described embodiments. Multiple display portable communication device 700 can include first flexible display 702 and second flexible display 704. In one embodiment, first flexible display 702 and second flexible display 704 can present visual content independent of each other. In alternative embodiments, first flexible display 702 and second flexible display 704 can cooperatively present visual content. For example, visual content can be presented by first flexible display 702 out of temporal phase with the visual content presented by second flexible display 704. In this way, an illusion of depth perception can be presented mimicking a 3D experience. In one embodiment, first flexible display 702 can be partially transparent such that visual content from second flexible display 704 can be viewed concurrent with visual content presented by first flexible display 702.

FIG. 7B shows a bottom view of multi-display portable electronic device 700 in accordance with the described embodiments.

FIG. 8 is a block diagram of an electronic device 800 suitable for use with the described embodiments. The electronic device 800 illustrates circuitry of a representative computing device. The electronic device 800 includes a processor 802 that pertains to a microprocessor or controller for controlling the overall operation of the electronic device 800. The electronic device 800 stores media data pertaining to media items in a file system 804 and a cache 806. The file system 804 is, typically, a storage disk or a plurality of disks. The file system 804 typically provides high capacity storage capability for the electronic device 800. However, since the access time to the file system 804 is relatively slow, the electronic device 800 can also include a cache 806. The cache 806 is, for example, Random-Access Memory (RAM) provided by semiconductor memory. The relative access time to the cache 806 is substantially shorter than for the file system 804. However, the cache 806 does not have the large storage capacity of the file system 804. Further, the file system 804, when active, consumes more power than does the cache 806. The power consumption is often a concern when the electronic device 800 is a portable media device that is powered by a battery 824. The electronic device 800 can also include a RAM 820 and a Read-Only Memory (ROM) 822. The ROM 822 can store programs, utilities or processes to be executed in a non-volatile manner. The RAM 820 provides volatile data storage, such as for the cache 806.

The electronic device 800 also includes a user input device 808 that allows a user of the electronic device 800 to interact with the electronic device 800. For example, the user input device 808 can take a variety of forms, such as a button, keypad, dial, touch screen, audio input interface, visual/image capture input interface, input in the form of sensor data, etc. Still further, the electronic device 800 includes a display 810 (screen display) that can be controlled by the processor 802 to display information to the user. A data bus 816 can facilitate data transfer between at least the file system 804, the cache 806, the processor 802, and the CODEC 813.

In one embodiment, the electronic device 800 serves to store a plurality of media items (e.g., songs, podcasts, etc.) in the file system 804. When a user desires to have the electronic device play a particular media item, a list of available media items is displayed on the display 810. Then, using the user

input device **808**, a user can select one of the available media items. The processor **802**, upon receiving a selection of a particular media item, supplies the media data (e.g., audio file) for the particular media item to a coder/decoder (CODEC) **813**. The CODEC **813** then produces analog output signals for a speaker **814**. The speaker **814** can be a speaker internal to the electronic device **800** or external to the electronic device **800**. For example, headphones or earphones that connect to the electronic device **800** would be considered an external speaker.

The electronic device **800** also includes a network/bus interface **811** that couples to a data link **812**. The data link **812** allows the electronic device **800** to couple to a host computer or to accessory devices. The data link **812** can be provided over a wired connection or a wireless connection. In the case of a wireless connection, the network/bus interface **811** can include a wireless transceiver. The media items (media assets) can pertain to one or more different types of media content. In one embodiment, the media items are audio tracks (e.g., songs, audio books, and podcasts). In another embodiment, the media items are images (e.g., photos). However, in other embodiments, the media items can be any combination of audio, graphical or visual content. Sensor **826** can take the form of circuitry for detecting any number of stimuli. For example, sensor **826** can include a Hall Effect sensor responsive to external magnetic field, an audio sensor, a light sensor such as a photometer, and so on.

The foregoing description, for purposes of explanation, used specific nomenclature to provide a thorough understanding of the described embodiments. However, it will be apparent to one skilled in the art that the specific details are not required in order to practice the described embodiments. Thus, the foregoing descriptions of the specific embodiments described herein are presented for purposes of illustration and description. They are not target to be exhaustive or to limit the embodiments to the precise forms disclosed. It will be apparent to one of ordinary skill in the art that many modifications and variations are possible in view of the above teachings.

The various aspects, embodiments, implementations or features of the described embodiments can be used separately or in any combination. Various aspects of the described embodiments can be implemented by software, hardware or a combination of hardware and software. The described embodiments can also be embodied as computer readable code on a computer readable medium for controlling manufacturing operations or as computer readable code on a computer readable medium for controlling a manufacturing line. The computer readable medium is any data storage device that can store data that can thereafter be read by a computer system. Examples of the computer readable medium include read-only memory, random-access memory, CD-ROMs, DVDs, magnetic tape, and optical data storage devices. The computer readable medium can also be distributed over network-coupled computer systems so that the computer readable code is stored and executed in a distributed fashion.

The foregoing description, for purposes of explanation, used specific nomenclature to provide a thorough understanding of the described embodiments. However, it will be apparent to one skilled in the art that the specific details are not required in order to practice the described embodiments. Thus, the foregoing descriptions of specific embodiments are presented for purposes of illustration and description. They are not intended to be exhaustive or to limit the described embodiments to the precise forms disclosed. It will be apparent to one of ordinary skill in the art that many modifications and variations are possible in view of the above teachings.

What is claimed is:

1. A consumer electronic product, comprising:
 - a transparent housing;
 - a flexible display assembly enclosed within the transparent housing, the flexible display assembly configured to present visual content at any portion of the transparent housing; and
 - a second flexible display assembly disposed within the flexible display assembly, wherein the flexible display assembly and the second flexible display assembly cooperatively present visual content.
2. The consumer electronic product as recited in claim 1, wherein the transparent housing has a conical cross section and a first and a second open end.
3. The consumer electronic product as recited in claim 2, wherein the flexible display is rolled up into a shape that conforms to the conical cross section and fits within the transparent housing.
4. The consumer electronic product as recited in claim 3, wherein the rolled up flexible display is inserted into the transparent housing.
5. A consumer electronic product, comprising:
 - a transparent housing, having a conical cross section and a first and a second open end; and
 - a flexible display assembly enclosed within the transparent housing, the flexible display assembly configured to present visual content at any portion of the transparent housing,
 wherein the flexible display is enclosed within the transparent housing by rolling the flexible display up into a shape that fits within the conical cross section, and fully inserting the rolled up flexible display into the transparent housing, and wherein subsequent to the insertion, the rolled up flexible display unrolls such that the unrolled flexible display conforms to an inside surface of the transparent housing.
6. The consumer electronic product as recited in claim 5, further comprising:
 - a processor;
 - a display; and
 - a detection mechanism that detects the presence of an end-user and determines a field of vision of the detected end-user.
7. The consumer electronic product as recited in claim 6, wherein the flexible display assembly only presents visual content in detected field of vision of the end-user.
8. The consumer electronic product as recited in claim 7, wherein the detection mechanism is an image capture device.
9. The consumer electronic product as recited in claim 8, wherein an image captured by the image capture device is processed by the processor using a facial recognition program to determine if the captured image includes a face of the end-user.
10. A method for assembly of a multi-display portable electronic device, comprising:
 - receiving a transparent enclosure;
 - shaping a flexible display to conform to a cross section of the transparent enclosure;
 - inserting the shaped flexible display into the transparent enclosure, wherein subsequent to the inserting, the shaped flexible display returns to an original shape that causes a display portion of the flexible display to press against an interior surface of the transparent enclosure; and
 - enclosing the inserted flexible display into the enclosure.
11. The method as recited in claim 10, wherein the flexible display is an AMOLED type display.

11

12. The method as recited in claim **10**, wherein the transparent enclosure is formed entirely of glass.

13. The method as recited in claim **12**, where a portion of the glass enclosure is masked to prevent an end-user from seeing an internal component.

14. The method as recited in claim **10**, further comprising:
prior to enclosing the inserted flexible display into the enclosure,

inserting a second flexible display within the inserted flexible display, wherein second flexible display and the inserted flexible display cooperatively present visual content.

15. The method as recited in claim **10**, wherein the portable electronic device includes an image capture device and a processor, the processor arranged to receive a captured image from the image capture device and process the captured image using a facial recognition computer code.

16. The method as recited in claim **15**, wherein the results of the processing of the captured image by the facial recognition computer code causes the processor to present visual content only on that portion of the transparent enclosure within a determined field of view of a facially recognized end user.

12

17. An apparatus for assembly of a multi-display portable electronic device, comprising:

means for receiving a transparent enclosure;

means for shaping a flexible display to conform to a cross section of the transparent enclosure;

means for inserting the shaped flexible display into the transparent enclosure, wherein subsequent to the inserting, the shaped flexible display returns to an original shape that causes a display portion of the flexible display to press against an interior surface of the transparent enclosure; and

means for enclosing the inserted flexible display into the enclosure.

18. The apparatus as recited in claim **17**, wherein the flexible display is an AMOLED type display.

19. The apparatus as recited in claim **17**, wherein the transparent enclosure is formed entirely of glass.

20. The apparatus as recited in claim **19**, where a portion of the glass enclosure is masked to prevent an end-user from seeing an internal component.

* * * * *