



US 20130145530A1

(19) **United States**

(12) **Patent Application Publication**
Mitra

(10) **Pub. No.: US 2013/0145530 A1**

(43) **Pub. Date: Jun. 13, 2013**

(54) **IRON MAN SUIT**

(52) **U.S. Cl.**

USPC 2/456

(76) Inventor: **Manu Mitra**, Walnut Creek, CA (US)

(21) Appl. No.: **13/316,420**

(57)

ABSTRACT

(22) Filed: **Dec. 9, 2011**

A suit apparatus constructed from a strong material, such as steel, which is capable of protecting its wearer from projectiles, such as bullets, and including a hydraulic mechanism and a power source, which enables the suit wearer to do mechanical work, such as pushing or lifting heavy objects, using the hydraulic mechanism.

Publication Classification

(51) **Int. Cl.**

A41D 13/00

(2006.01)

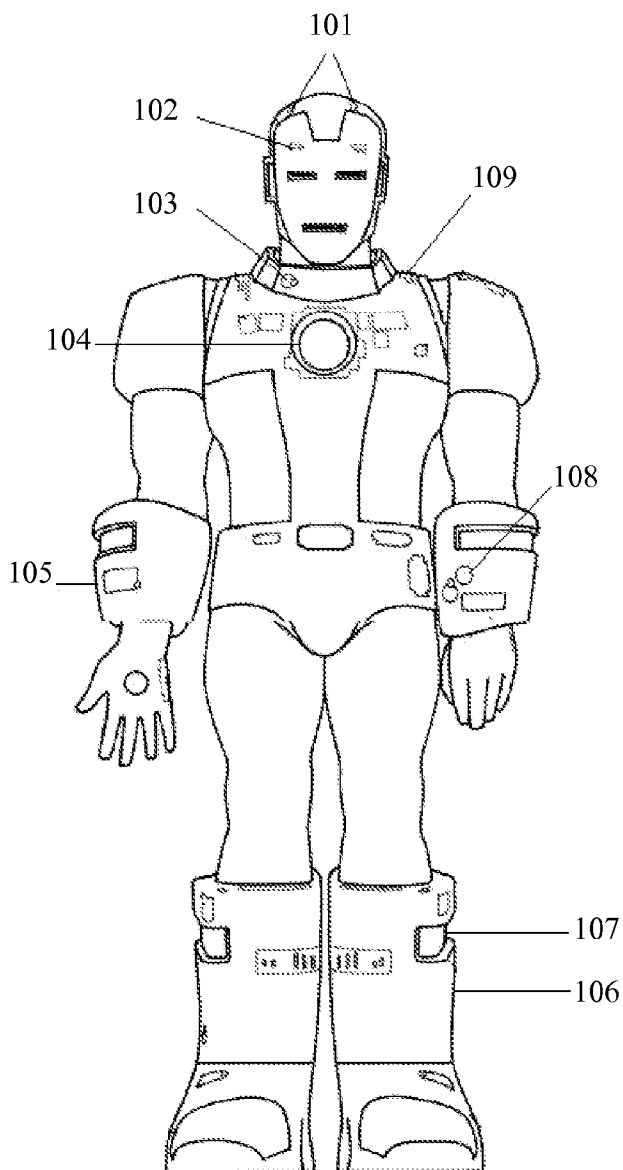

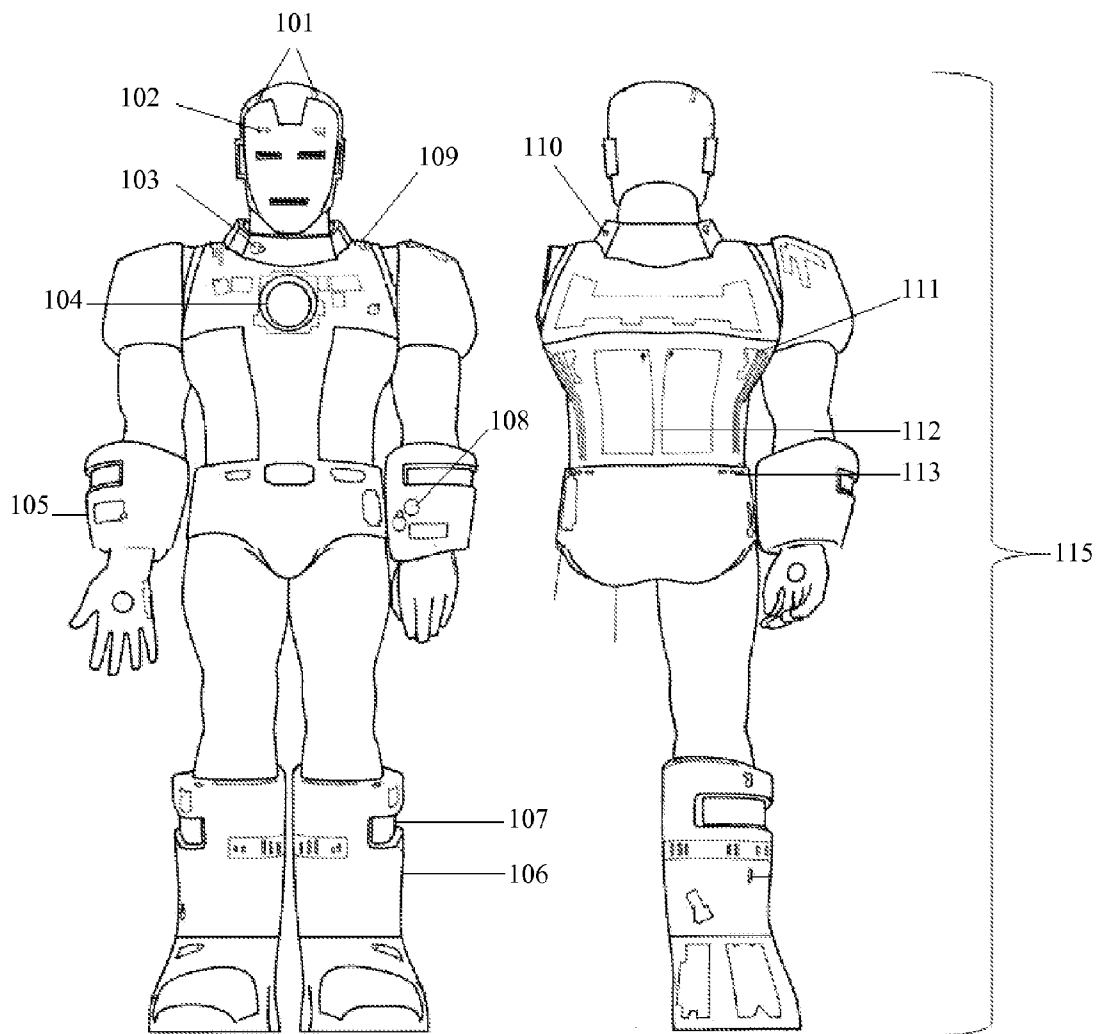

FIG. 1a

FIG. 1b

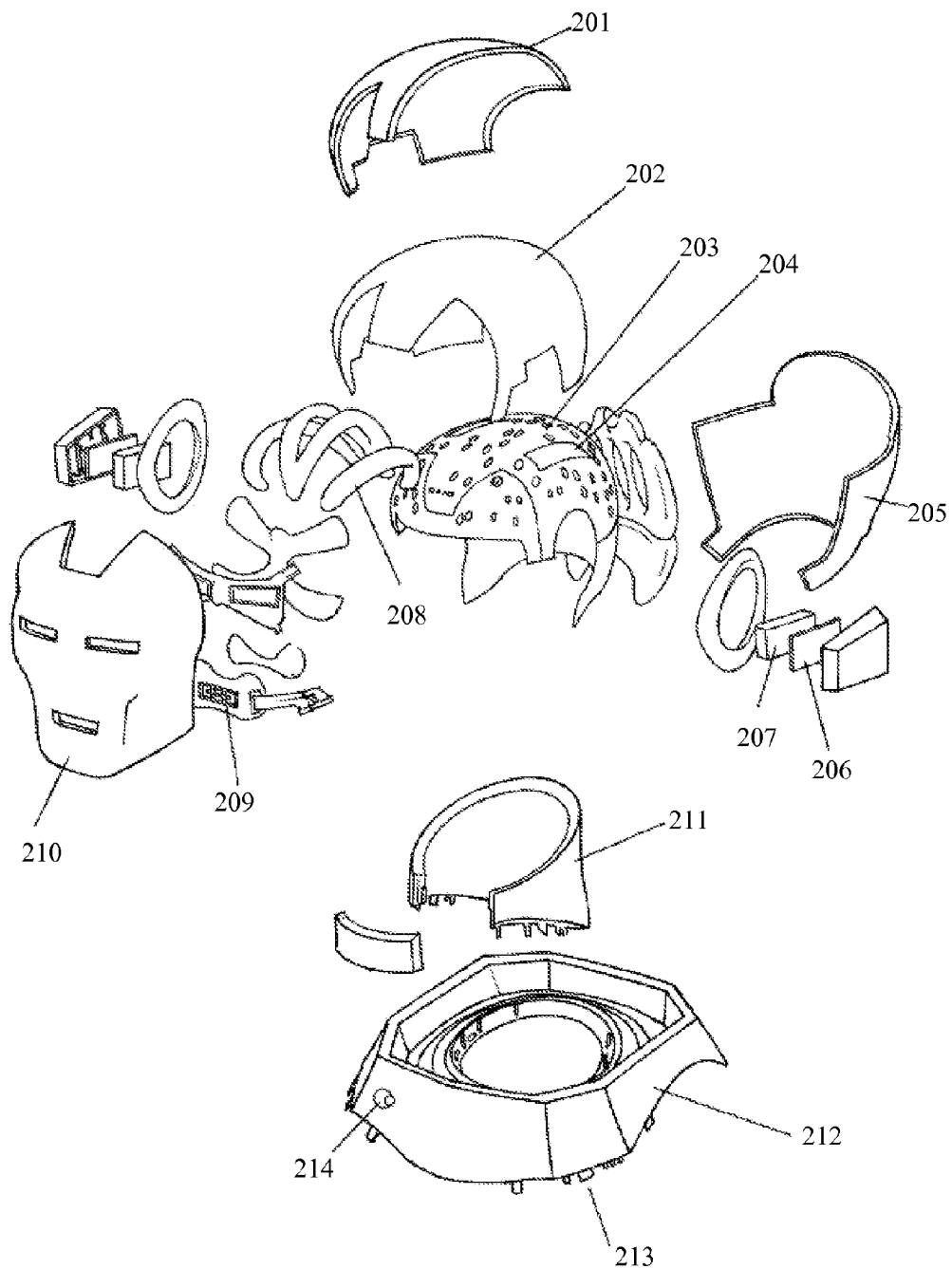

FIG. 2

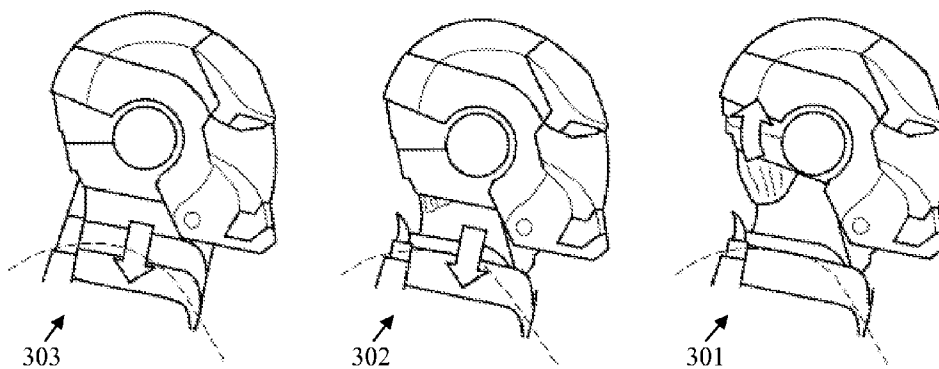

FIG. 3

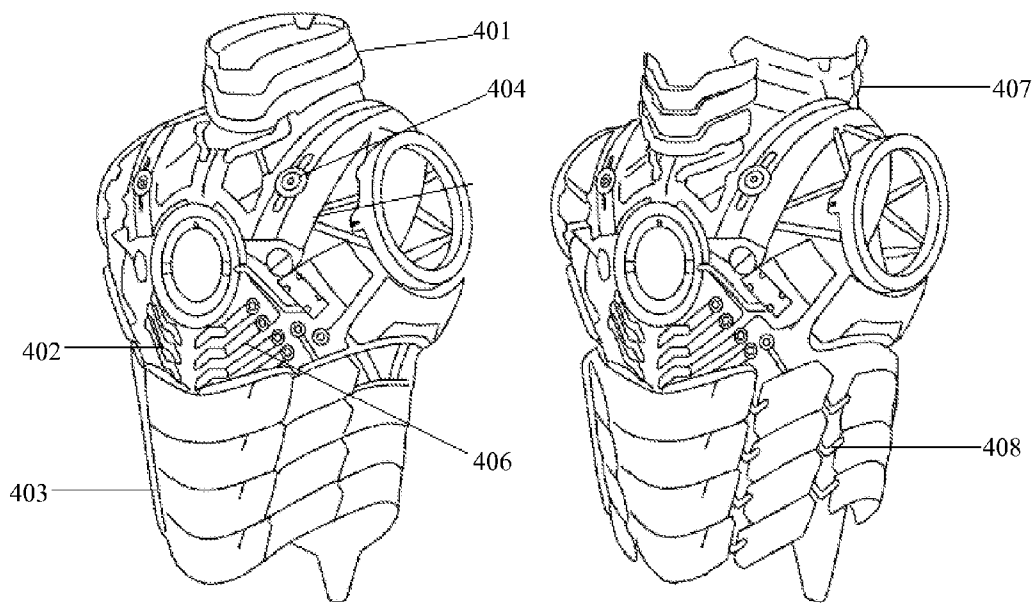

FIG. 4a

FIG. 4b

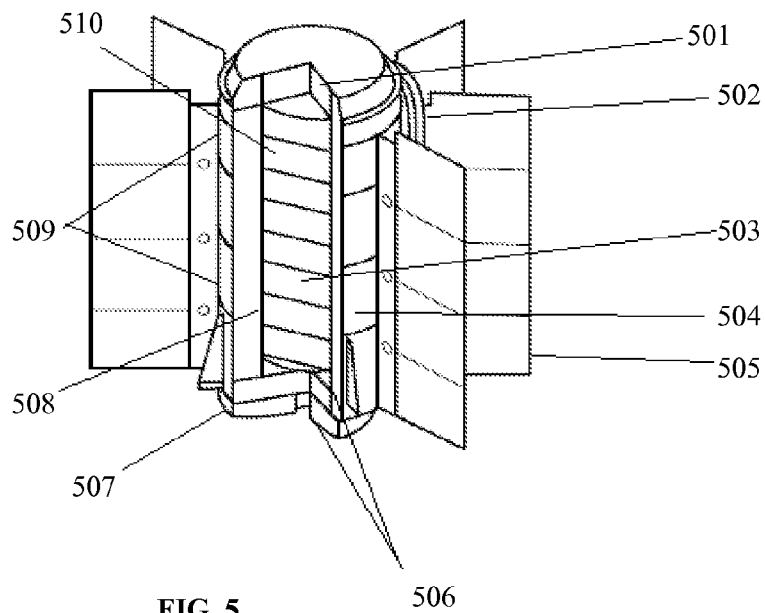

FIG. 5

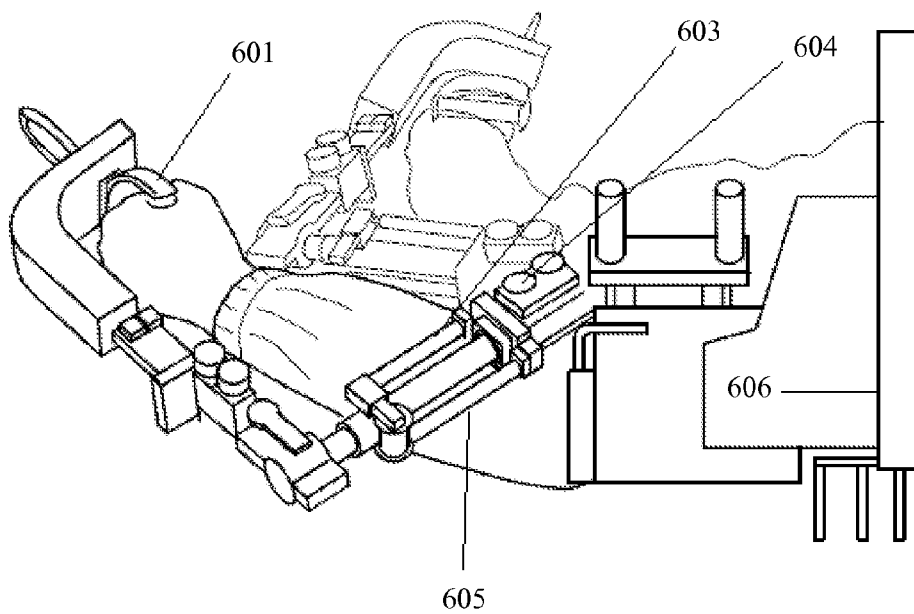

FIG. 6

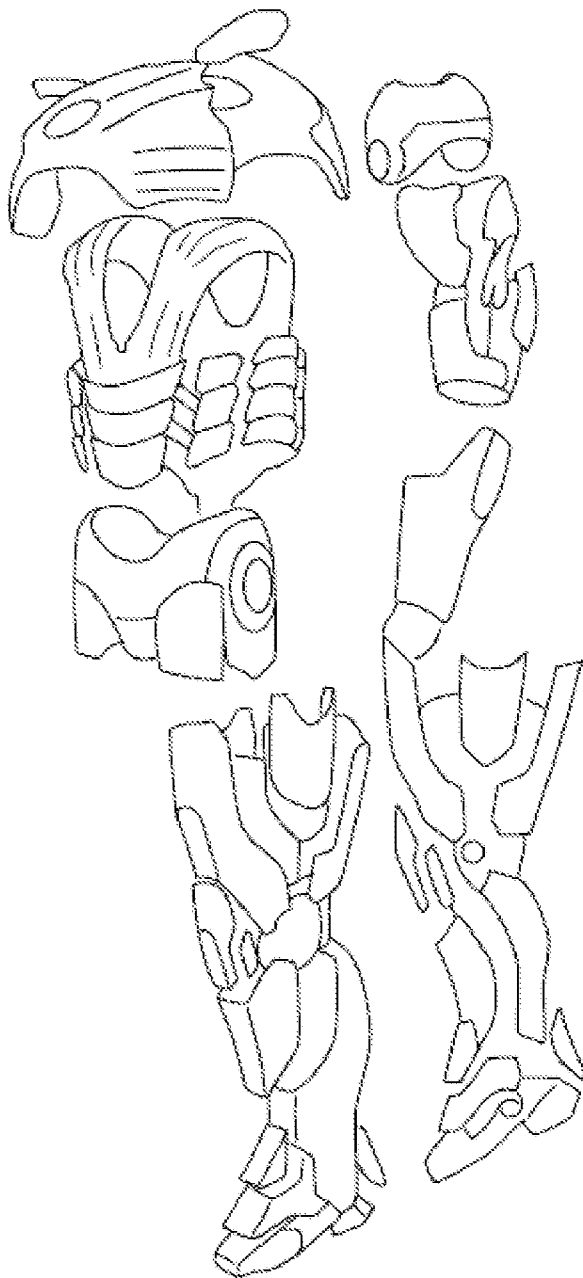

FIG. 7

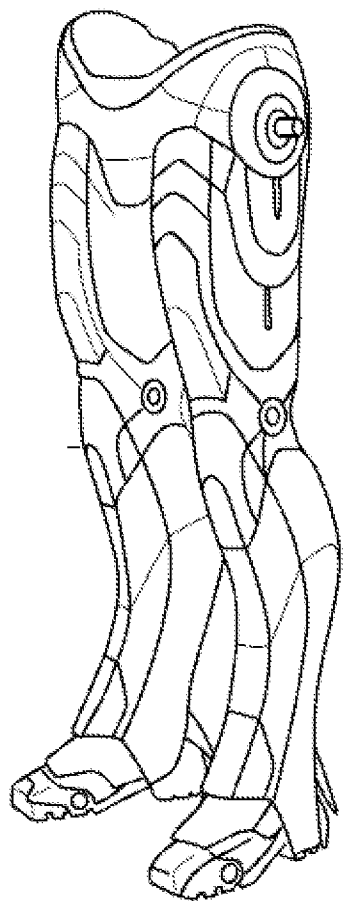

FIG. 8a

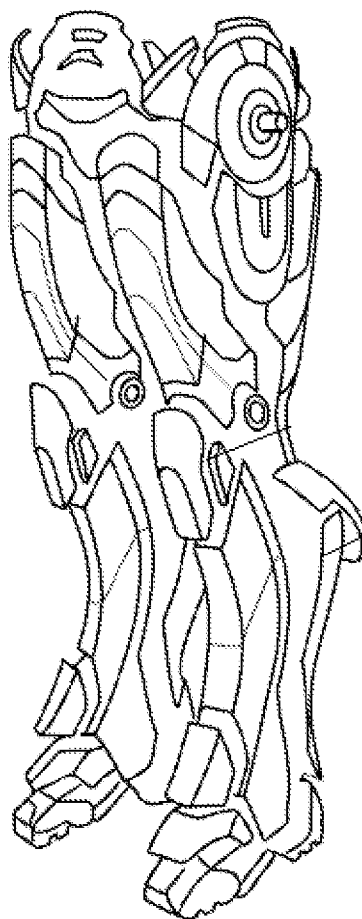

FIG. 8b

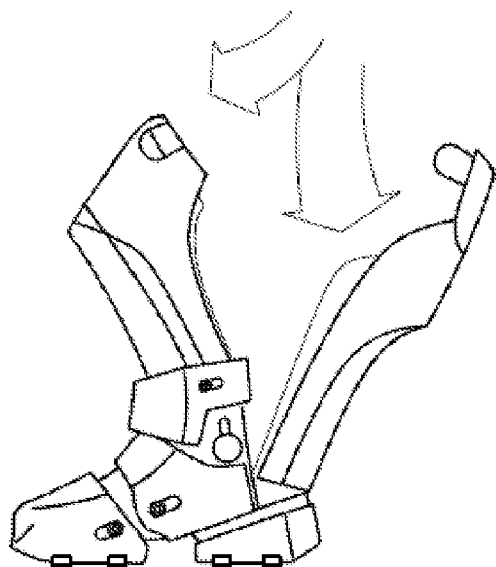

FIG. 9a

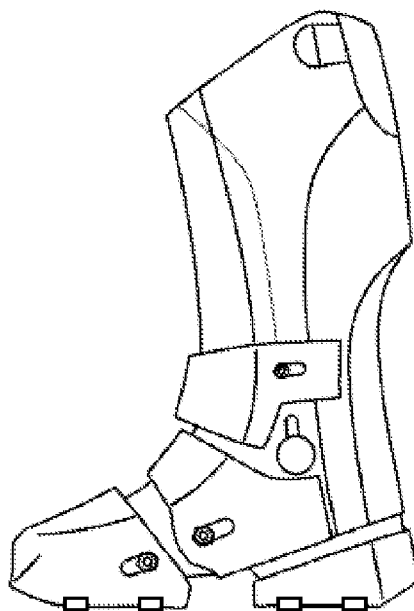

FIG. 9b

IRON MAN SUIT

CROSS-REFERENCE TO RELATED APPLICATIONS

[0001] Not Applicable

STATEMENT REGARDING FEDERALLY SPONSORED RESEARCH OR DEVELOPMENT

[0002] Not Applicable

REFERENCE TO SEQUENCE LISTING, A TABLE, OR A COMPUTER PROGRAM LISTING COMPACT DISC APPENDIX

[0003] Not Applicable

BACKGROUND OF THE INVENTION

[0004] 1. Field of the Invention:

[0005] The invention relates generally to electronics and mechanics and more particularly to an improved wearable suit apparatus made of strong material.

[0006] 2. Description of the Related Art

[0007] While it appears that attempts were previously made to design ironman like suits, the need for a new, improved and integrated suit apparatus, which enables a suit wearer to, among other things, be protected from projectiles, lift heavy objects, and communicate with others, still exists.

BRIEF SUMMARY OF THE INVENTION

[0008] This Summary is provided to introduce a selection of concepts in a simplified form that are further described below in the Detailed Description. This Summary is not intended to identify key aspects or essential aspects of the claimed subject matter. Moreover, this Summary is not intended for use as an aid in determining the scope of the claimed subject matter.

[0009] In one exemplary embodiment a plated suit is combined with an integrated automatic hydraulic system and a power source. Thus, an advantage is that the suit can protect the suit wearer from projectiles such as bullets. Another advantage is that the suit wearer can perform extraordinary mechanical work such as pushing or lifting heavy objects.

[0010] In another exemplary embodiment the suit also incorporates sensors, a computer, a camera and communication means. Thus, an advantage is the ability of the suit wearer to collect information about the surroundings and to process, use or communicate that information to others.

[0011] The above embodiments and advantages, as well as other embodiments and advantages, will become apparent from the ensuing description and accompanying drawings.

BRIEF DESCRIPTION OF THE DRAWINGS

[0012] For exemplification purposes, and not for limitation purposes, embodiments of the invention are illustrated in the figures of the accompanying drawings, in which:

[0013] FIGS. 1a-b illustrate a front view and a partial back view of the suit, respectively.

[0014] FIG. 2 shows an exploded view of the head portion of the suit.

[0015] FIG. 3 illustrates various stages of the automatic refraction, and locking of the head portion of the suit.

[0016] FIGS. 4a-b are perspective views of an exemplary chest armor, in locked and unlock position, respectively.

[0017] FIG. 5 illustrates an exemplary arc reactor.

[0018] FIG. 6 illustrates an exemplary hydraulic mechanism integrated in the suit.

[0019] FIG. 7 illustrates a partial exploded view of the suit.

[0020] FIGS. 8a-b illustrate an exemplary leg portion of the suit in locked and unlocked position, respectively.

[0021] FIGS. 9a-b illustrate an exemplary boot portion of the suit in unlocked and locked position, respectively.

DETAILED DESCRIPTION OF THE PREFERRED EMBODIMENTS

[0022] What follows is a detailed description of the preferred embodiments of the invention in which the invention may be practiced. Reference will be made to the attached drawings, and the information included in the drawings is part of this detailed description. The specific preferred embodiments of the invention, which will be described herein, are presented for exemplification purposes, and not for limitation purposes. It should be understood that structural and/or logical modifications could be made by someone of ordinary skills in the art without departing from the scope of the invention. Therefore, the scope of the invention is defined by the accompanying claims and their equivalents.

[0023] The inventive apparatus is a full body clothing article, constructed of integrated, strong material (e.g., plated boots, plated gloves, plated jacket, etc.) and equipped with sensors to detect body movements, automatic hydraulics mechanism to lift heavy objects, actuators and controllers to bear the weight of an object and at least one power supply. Additional components and functions may be added to the suit, as it will be explained below.

[0024] Referring to FIGS. 1a-b, there is illustrated a new and improved Iron Man Suit apparatus 115. FIG. 1a is a front view and FIG. 1b is a partial back view of the suit, respectively. The following components of the suit are depicted in FIGS. 1a-b: UHF/VHF antenna array 101, camera platform 102, suit safety seals 103, shock mount plate 104, display panel 105, plated boots 106, surplus heat radiator panels 107, power control panel 108, forward looking micro pulse radar port 109, collar assembly cooling access 110, micro pulse radar port 111, suit respiration control field 112, and atmospheric distillation inlet 113.

[0025] Antennas are generally used for communication. Here, the antenna array 101 may be used, for example, to transmit and receive voice or video signals. It allows the suit wearer to receive and transmit signals from/to, for example, other suit wearers or a command center.

[0026] A camera is a device that records and stores images. These images may be still photographs or moving images such as videos or movies. Here, a camera 102 is integrated into the suit which allows the suit wearer to take images. Such images may have several uses. For example, the images may be used to create a record of the activity of the suit wearer. Such a record may be valuable in, for example, investigating an accident that may have occurred during use of the suit by the wearer.

[0027] The suit safety seals 103 may have button-like functionality and they allow the suit wearer to secure the suit onto the wearer. They are used to better protect the wearer while allowing for better mobility and faster donning. The suit safety seals 103 are made of metal or composite materials.

[0028] The shock mount plate 104 is used to mount a power source onto the suit. Such power source may be an arc reactor

or a battery pack. The power source supplies power as needed to power different components in the suit.

[0029] The display panel 105 may be used to display various information, which may be useful to the suit wearer. Such information may be related to battery level, time, etc.

[0030] The plated boots 106 may be covered with protective plates or sheets of strong material such as steel. They allow the suit wearer, to some extent, to be protected from injury by blocking various objects from penetrating the boots and injure the suit wearer. As it may be the case with the entire suit, the boots may be only partially plated, in order to reduce the weight of the suit, and thus, facilitate mobility of the wearer. It should be noted, that less plating, while increasing mobility, it also increases the risk of injury to the suit wearer. Thus, a balancing approach has to be instituted, based on the type of missions the suit is designed to be employed for.

[0031] Heat radiators are commonly used to transfer heat energy from one place to another, in which the radiator cools the object by transferring heat energy from the object to the air. The surplus heat radiator panels 107 are used in the suit to transfer heat energy generated by the body of the suit wearer and/or by various components of the suit. The surplus heat radiator panels 107 may be placed at one or more locations on the suit, as needed.

[0032] The power control panel 108 may include a general switch that turns on and off the power to all suit components, and/or separate switches and/or dial meters for each individual component of the suit that needs power in order to function. Thus, the power control panel 108 allows the suit wearer to control the power that is supplied to various components of the suit.

[0033] The forward looking micro pulse radar 109 allows the suit wearer to determine the range, altitude, direction, or speed of both moving and fixed objects. The determined values of the respective parameters may be displayed on the display panel 105, and/or communicated to a command center via, for example, satellite communication, and/or audio communicated to the suit wearer directly or indirectly (i.e., from the command center).

[0034] The collar assembly cooling access 110 allows the suit wearer relief from heat generated by his/her body and/or suit components, and from heat accumulated by the suit from the environment. It may include a cooling fan to expedite the cooling process. Cooling accesses may be placed at one or more locations on the suit, as needed.

[0035] The micro pulse radar port 111 may be similar in design and function as the radar used for forward looking micro pulse radar 109 described above. The difference may be that it determines the range, altitude, direction, or speed of both, moving and fixed objects, in opposite direction (e.g., behind or lateral of the suit wearer). Again, the determined values of the respective parameters may be displayed on the display panel 105, and/or communicated to a command center via, for example, satellite communication, and/or audio communicated to the suit wearer directly or indirectly (i.e., from the command center).

[0036] The suit respiration control field 112 may also be used to cool the suit and the suit wearer. It may include vent(s), air filter(s) and/or cooling fan (s). The atmospheric distillation inlet 113 may work in conjunction with the suit respiration control field 112, and may also include vent(s), air filter(s) and/or cooling fan (s). It should be appreciated that the suit respiration control field 112 and the atmospheric distillation inlet 113 may be placed in other areas of the suit,

as needed for a proper cooling of the suit and suit wearer in the specific work conditions for which the suit is designed.

[0037] Referring to FIG. 2, an exploded view of the head portion of the suit is shown. The following are the components depicted: outer head casing 201, internal head casing with neural processor 202, antenna array 203, sub routine processor 204, rear head piece 205, audio processor 206, transducer array 207, internal padding 208, vocal harmonizer 209, face piece 210, neck assembly 211, neck cowl assembly 212, port suit connection 213, and suit safety seals 214.

[0038] The outer head casing 201, the rear head piece 205, the face piece 210, the neck assembly 211 and the neck cowl assembly 212 are used to protect the head, face and neck of the suit wearer from impact injury. They are made of strong materials such as metal or composite materials.

[0039] The internal head casing with neural processor 202, antenna array 203, sub routine processor 204, audio processor 206, vocal harmonizer 209, transducer array 207 are all standard components known in the art. They are part of the suit communication system, enabling the suit wearer to communicate with, for example, other suit wearers or a command center.

[0040] Referring to FIG. 3, various stages of the automatic retraction, and locking of the helmet (i.e., head portion of the suit) are depicted therein. Namely, the unlocked 301, prior-to-locking 302 and locked 303 positions, respectively, are shown. The automatic retraction of the helmet is controlled by a manual button (not shown in the figure).

[0041] Referring to FIGS. 4a and 4b, an exemplary chest armor (i.e., chest portion of the suit) is shown, in locked and unlock position, respectively. The following are the components depicted: locked neck cowl 401, integrated parts for right rib protection 402, locked stomach plate 403, shoulder strap belt 404, integrated parts for left rib protection 406, unlocked neck cowl 407, and unlocked stomach plate 408.

[0042] The integrated parts for right rib protection 402, the integrated parts for left rib protection 406, the neck cowl 401 and the stomach plate 403 are made from strong material like metal or composite material. As is the case with all the other plates of the suit, they are used to protect the suit wearer from blows and other projectile weapons.

[0043] The shoulder strap belt 404 is used to allow the suit wearer to adjust the size of the suit according to the size and comfort of the suit wearer.

[0044] The stomach plate 403 is resizable and can be locked and unlocked. This is allowed by a construction of the stomach plate 403 from smaller plates connected by hinges or similar articulations known in the art.

[0045] Referring to FIG. 5, an exemplary arc reactor is shown. The components of a possible construction of a portable arc reactor are depicted, as follows: thermal insulation 501, cooling tubes 502, module stack 503, housing 504, fin 505, thermal insulation 506, mounting interface 507, heat distribution block 508, thermoelectric modules 509, and heat source liner 510.

[0046] Referring to FIG. 6, an exemplary automatic hydraulic mechanism is shown, which may be integrated in the suit in order to enable the suit wearer to perform extraordinary mechanical work, such as lifting or pushing heavy objects, which would be otherwise impossible using only the human body's power. The following components of the automatic hydraulic mechanism are depicted, as follows: sensors 601, cylinder actuator 603, valves 604, cables 605, and computer 606. It should be apparent that the hydraulic system

would also include hydraulic lines (not shown) and one or more hydraulic pumps (not shown).

[0047] The suit may be configured such that when the suit wearer will attempt to lift a heavy object, one or more sensors 601 will detect the attempt and will also collect information that would help determine or estimate the weight of the object. This information will then be sent to the computer 606, which will process the information and send a command through cables 605 to cylinder actuator 603 to engage and to produce an adequate hydraulic power.

[0048] The cylinder actuator 603 is a device that converts hydraulic power into useful mechanical work by means of a tight piston moving in a closed cylinder.

[0049] Referring to FIG. 7, a partial exploded view of the suit is depicted. As shown, the suit may be constructed to function as body armor. The plate-based design of the suit permits greater mobility of the wearer while still providing a high degree of protection.

[0050] Referring to FIGS. 8a and 8b, an exemplary leg portion of the suit in locked and unlocked position, respectively, is shown. Similarly, in FIGS. 9a and 9b, an exemplary boot portion of the suit in unlocked and locked position, respectively, is shown.

[0051] Again, the inventive apparatus is a full body clothing article, constructed of integrated, strong material (e.g., plated boots, plated gloves, plated jacket, etc.) and equipped with sensors to detect body movements, hydraulics mechanism to lift heavy objects, actuators and controllers to bear the weight of an object and at least one power supply. Additional components and functions may be added to the suit, as explained above.

[0052] It should be understood that sensors may be placed on different sections or components of the suit, as needed. Sensors may be used to detect the movement of the wearer.

[0053] The inventive suit can be used in military applications and logistics. The suit also affords the wearer with protection against directed projectile weapons, at least to a certain extent.

[0054] In addition to providing adequate protection from the projectile weapons, the inventive clothing preferably also provides flame resistance, wear resistance, ease of cleaning and maintenance, and wearer acceptance and comfort.

[0055] It may be advantageous to set forth definitions of certain words and phrases used in this patent document. The term “couple” and its derivatives refer to any direct or indirect communication between two or more elements, whether or not those elements are in physical contact with one another. The terms “include” and “comprise,” as well as derivatives thereof, mean inclusion without limitation. The term “or” is inclusive, meaning and/or. The phrases “associated with” and “associated therewith,” as well as derivatives thereof, may mean to include, be included within, interconnect with, contain, be contained within, connect to or with, couple to or with, be communicable with, cooperate with, interleave, juxtapose, be proximate to, be bound to or with, have, have a property of, or the like.

[0056] Although specific embodiments have been illustrated and described herein for the purpose of disclosing the preferred embodiments, someone of ordinary skills in the art

will easily detect alternate embodiments and/or equivalent variations, which may be capable of achieving the same results, and which may be substituted for the specific embodiments illustrated and described herein without departing from the scope of the invention. Therefore, the scope of this application is intended to cover alternate embodiments and/or equivalent variations of the specific embodiments illustrated and/or described herein. Hence, the scope of the invention is defined by the accompanying claims and their equivalents. Furthermore, each and every claim is incorporated as further disclosure into the specification and the claims are embodiment(s) of the invention.

What is claimed is:

1. A suit apparatus comprising: a full body clothing article constructed at least in part from a strong material capable of protecting the wearer of said full body clothing article from projectiles; at least one hydraulic mechanism associated with said full body clothing article and carried by the wearer of said full body clothing article; a power source associated with and carried on said full body clothing article, wherein the power source is capable of supplying power to said hydraulic mechanism, which, when actuated, enables the wearer of said full body clothing article to do mechanical work using said hydraulic mechanism; and at least one sensor associated with said full body clothing article and capable of detecting the body movement of the wearer of said full body clothing article.

2. The suit apparatus of claim 1, further comprising at least one micro pulse radar, which permits the determination of the value of at least one parameter which is the member of a group consisting of the range, altitude, direction, and speed of both moving and fixed objects.

3. The suit apparatus of claim 1, further comprising communication means which allow the wearer of said full body clothing article to communicate with others.

4. The suit apparatus of claim 1, further comprising a camera that records and stores images.

5. The suit apparatus of claim 4, wherein said images comprise motion pictures.

6. The suit apparatus of claim 1, further comprising means for cooling down said full body clothing article and its wearer.

7. The suit apparatus of claim 1, further comprising a display panel capable of displaying data.

8. The suit apparatus of claim 1, further comprising at least one computer capable of controlling the function of said hydraulic mechanism.

9. The suit apparatus of claim 1, wherein said strong material is steel.

10. The suit apparatus of claim 1, wherein said projectiles comprise bullets.

11. The suit apparatus of claim 1, wherein said power source comprises at least one battery.

12. The suit apparatus of claim 1, wherein the actuation of said hydraulic mechanism is performed by a computer based on the information received by said computer from said at least one sensor.

13. The suit apparatus of claim 1, wherein said mechanical work comprises pushing a heavy object.

* * * * *